

Week 8: Product Design - Advanced Assembly & Rest of Design Process

Concepts

- Continuing Bluetooth Speaker project
- Using Linked Documents for standard hardware
- Advanced Assembly concepts
- Applying “snap mode” in Assembly
- Grouping in Assembly
- Replicating for fasteners

Models

- Finished Bluetooth Speaker document, including assembly, drawing, etc.



Bluetooth Speaker Continued

In this lesson, we will finish our Bluetooth speaker design by creating the battery pack, and assembling all of the parts with the correct hardware. During assembly, we will leverage advanced assembly tools like Snap Mode, Group, and Replicate. At the end of this lesson our design will be complete!

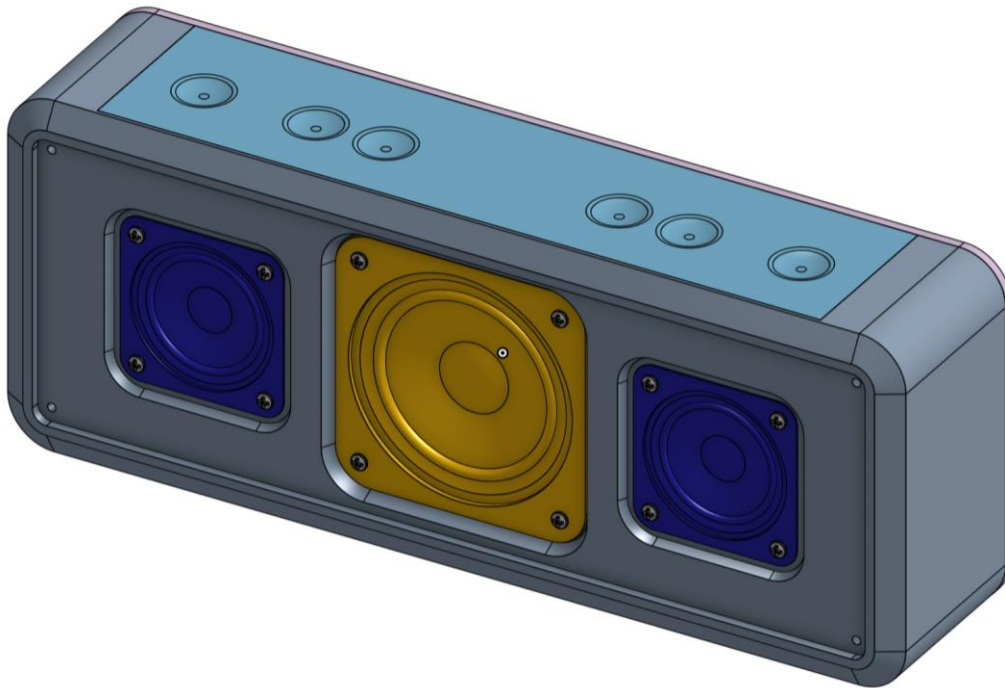

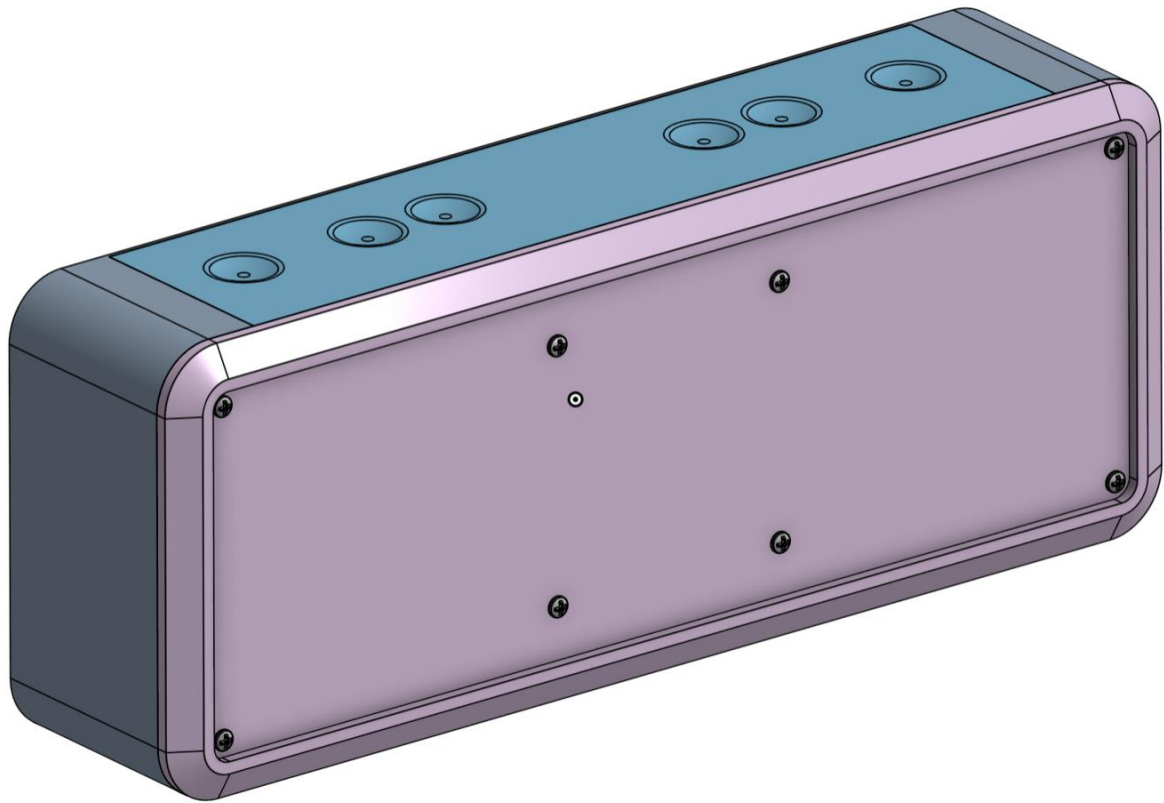

Design Intent Check: We're going to be making the batteries in another Part Studio. The batteries will fit in the bottom of the speaker and will be covered by the battery cover and stand (not shown in the pictures below). We'll be mating the batteries at the end of the lesson.

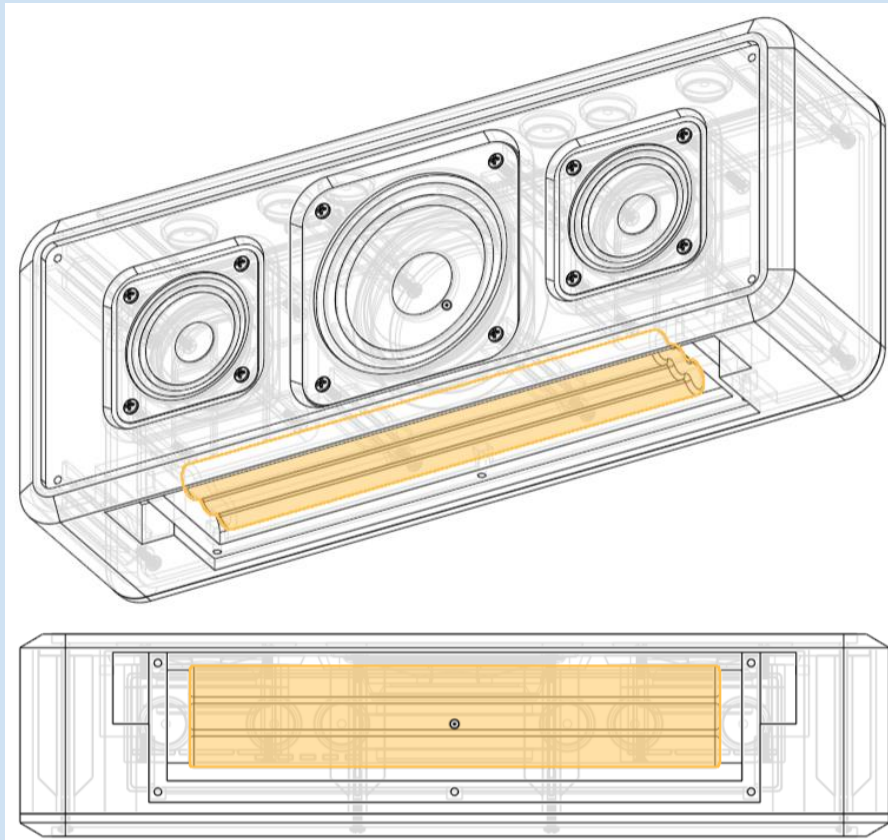

1. Before we start assembling, we need to build our Lithium Ion battery pack. Start by opening our document, and creating a new Part Studio Tab (click the + button in the bottom left corner). Let's name the Part Studio "Batteries". Start by creating a sketch on the Front Plane (use constraints as necessary to achieve a fully constrained sketch):

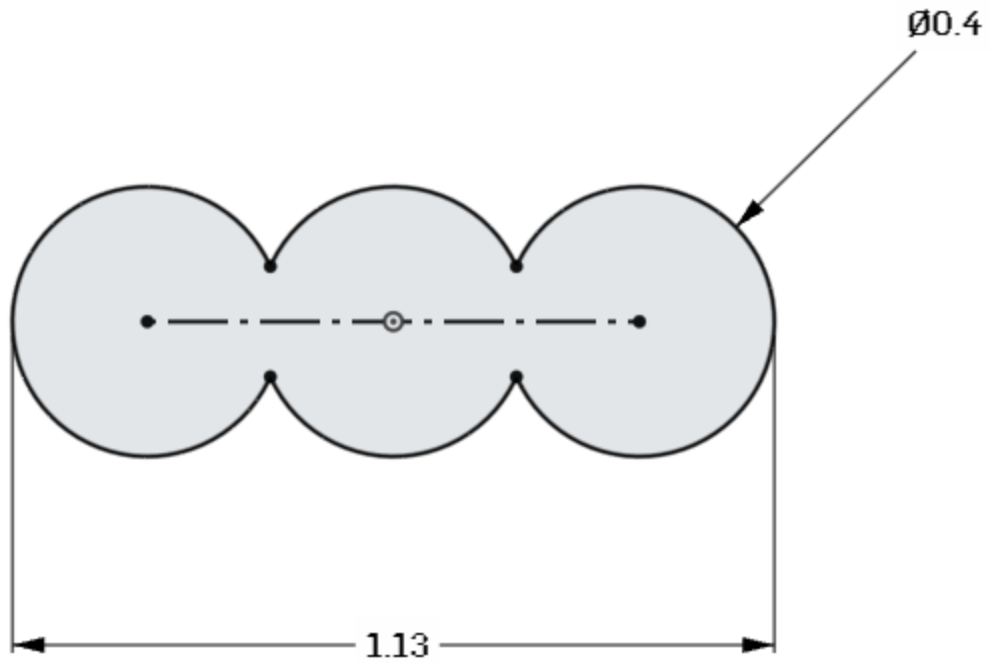

2. Next, extrude it out symmetrically:

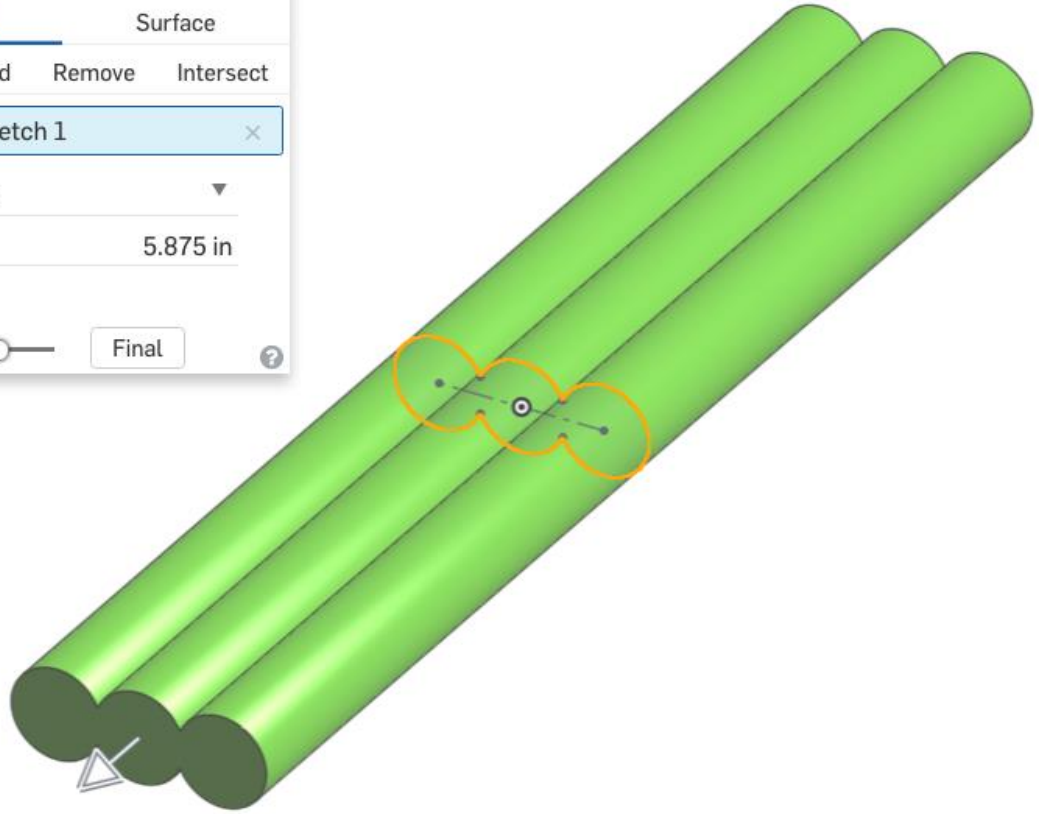
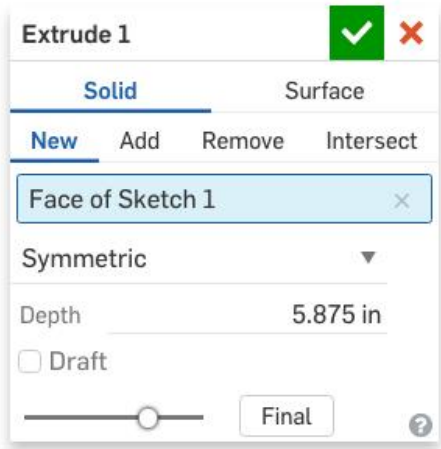

3. Next, create a 0.05" fillet on both ends:

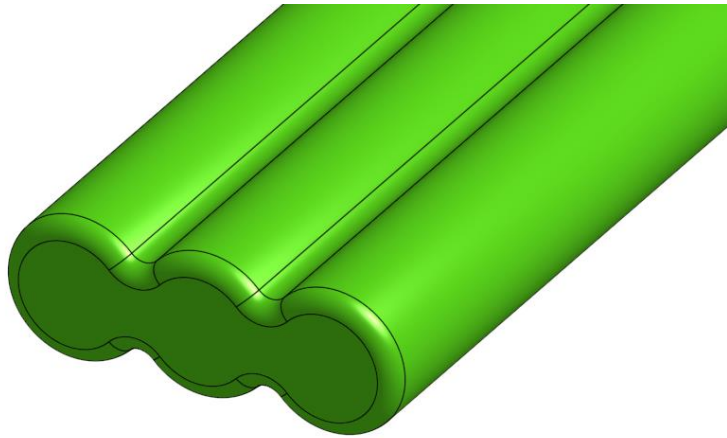

4. Finally, let's add a Mate Connector, as this will allow us to assemble it easily. Unhide the original sketch, and click on Mate Connector . A dialog box will show up, but we can ignore it for now. Place the Mate Connector at the center, making sure the Blue axis is pointed towards the right side, like this:

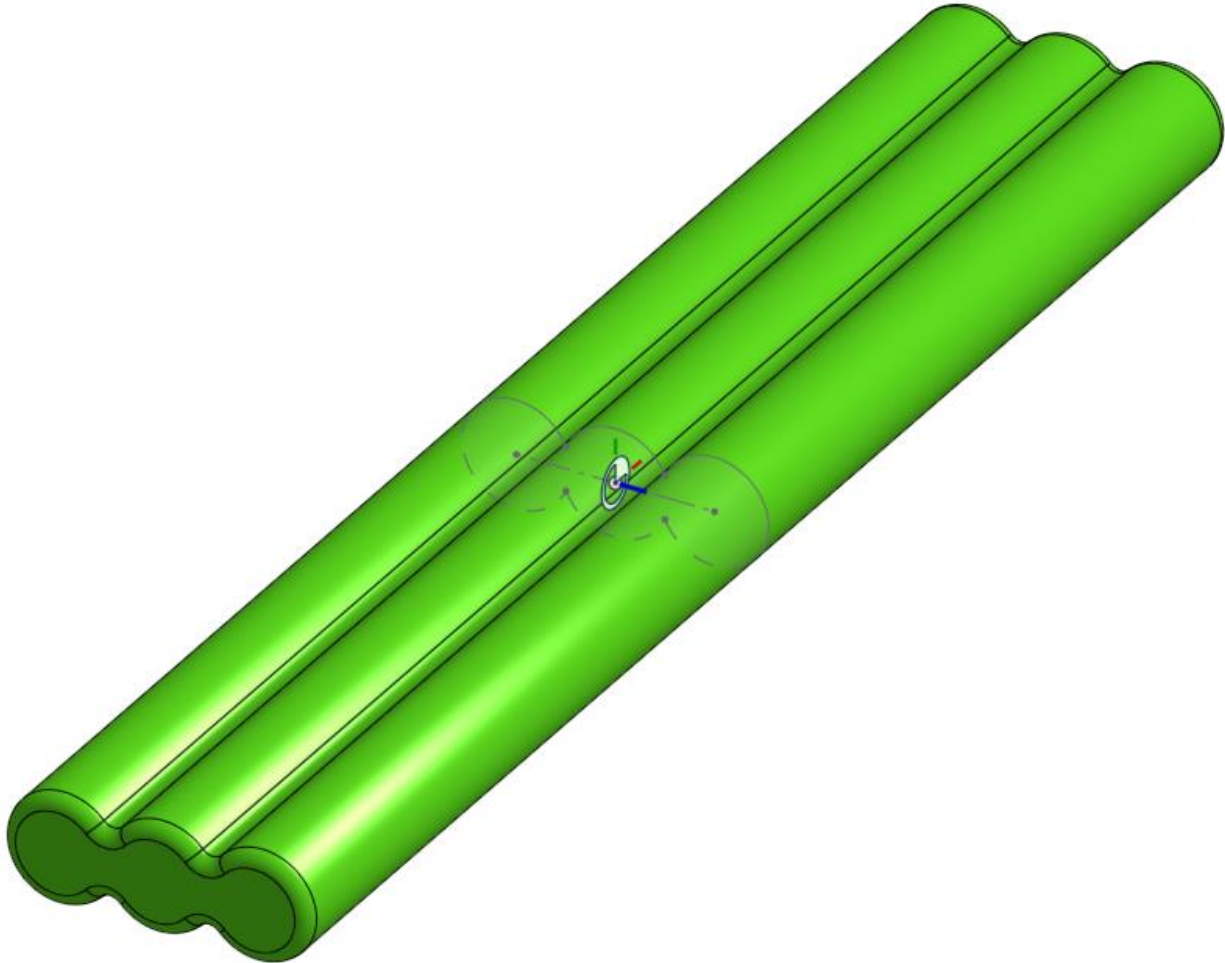

Pro Tip: Adding a Mate Connector here (within the Part Studio) is a good idea when there is no readily available geometry to easily Mate the part to the assembly. In real life, this battery pack is installed during assembly and just “floats” in place in the battery compartment. From a design standpoint, it’s best to just place it in the center of the compartment. Since there is no geometry to signify the center of the battery pack, we’ll use the sketch here. In this case, we strategically built the model in a way that we could take advantage of this. This is a great example of thinking ahead, and utilizing design intent.

5. Notice that the Mate Connector dialog box was automatically filled out. Click the green check. Okay, now we are ready to assemble the Bluetooth speaker. First, let's open our assembly tab, and select “Insert”. Click on the Speaker Studio which has our Bluetooth Speaker design in it:

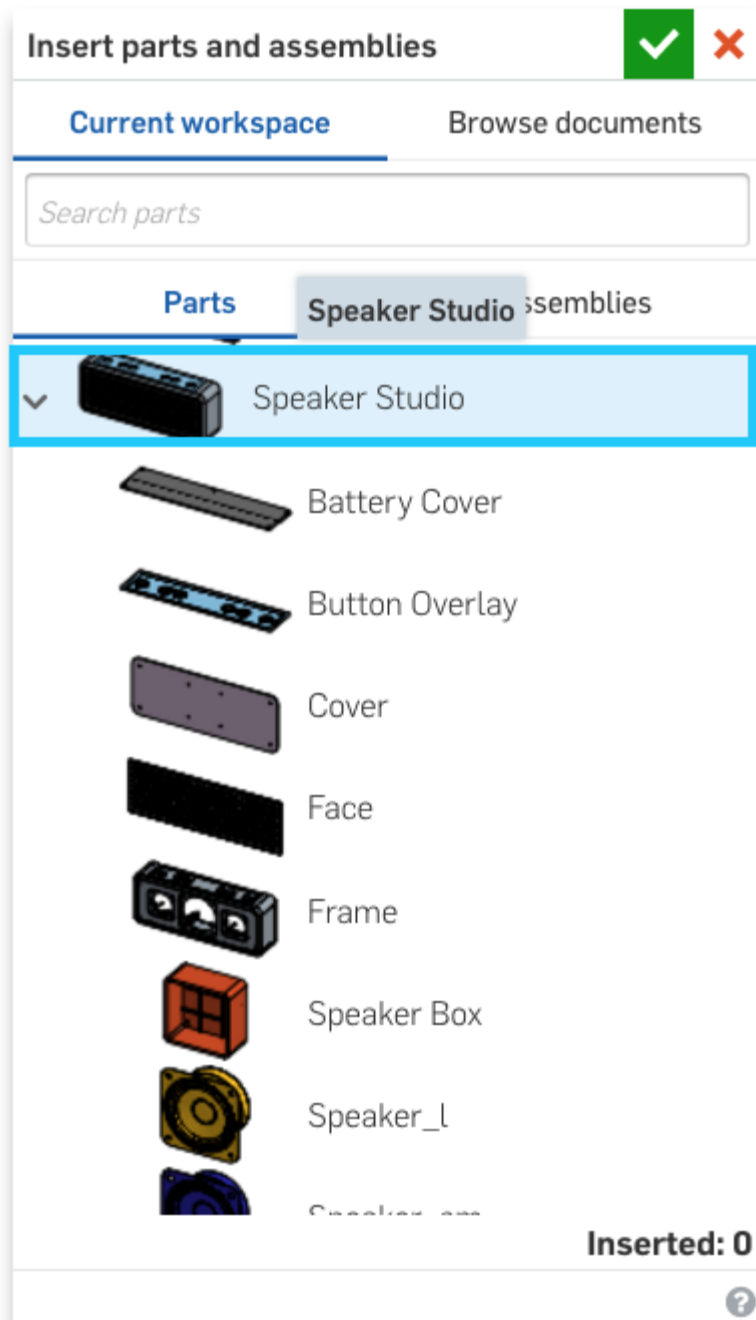



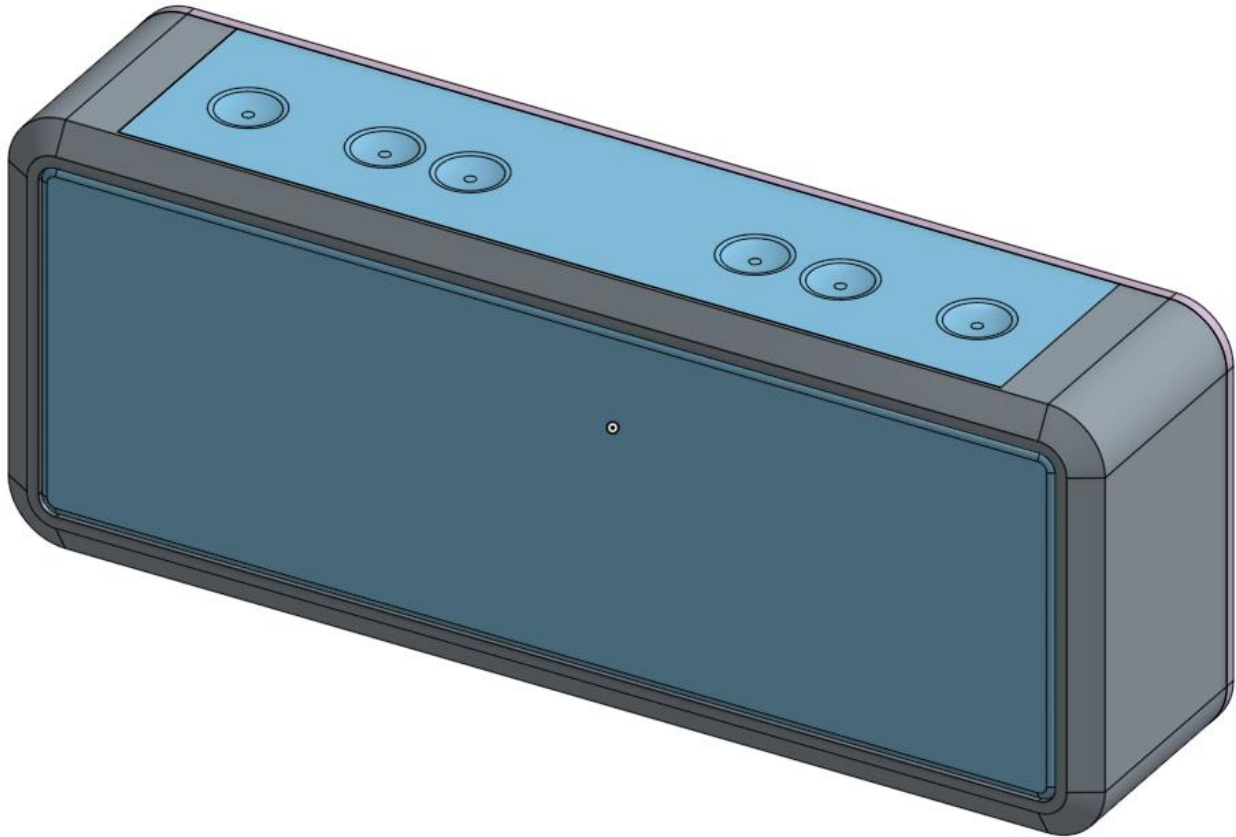





6. Now, just click the Green check box. This will drop everything from our design into our Assembly Studio in it's default location (the location it was designed in):



7. Next, let's fix everything in our Assembly, except for the stand. The Part List should now look like this:

Instances (9)

- Origin
- 📄 Battery Co... 
- 📄 Button Ove... 
- 📄 Cover <1> 
- 📄 Face <1> 
- > 📄 Frame <1> 
- 📄 Speaker B... 
- 📄 Speaker_la... 
- 📄 Speaker_s... 
- 📄 Stand <1>

Design Intent Check: We want our stand to swing open to prop the speaker up. How should we mate the stand to the rest of the speaker? What should the limits be?

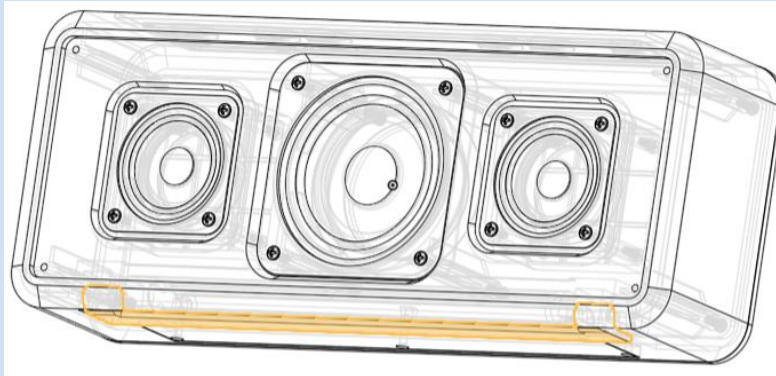

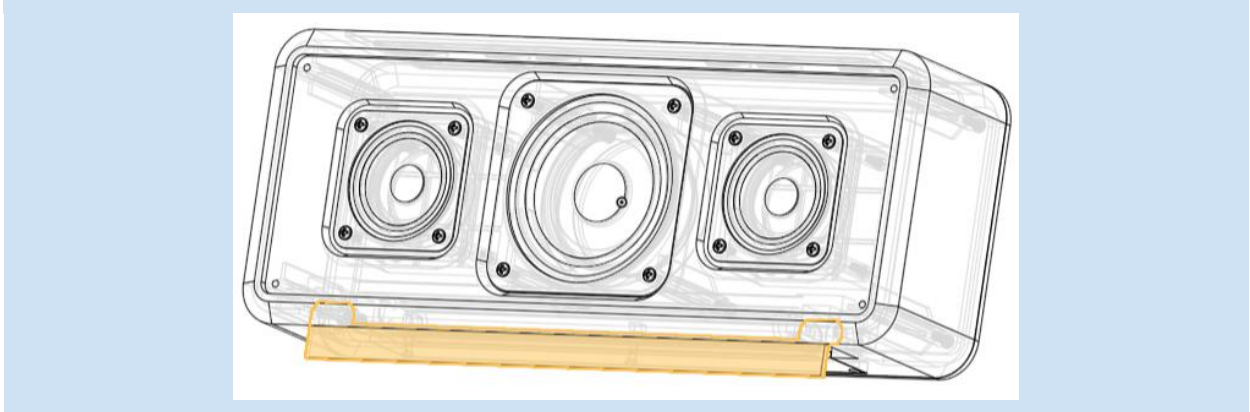

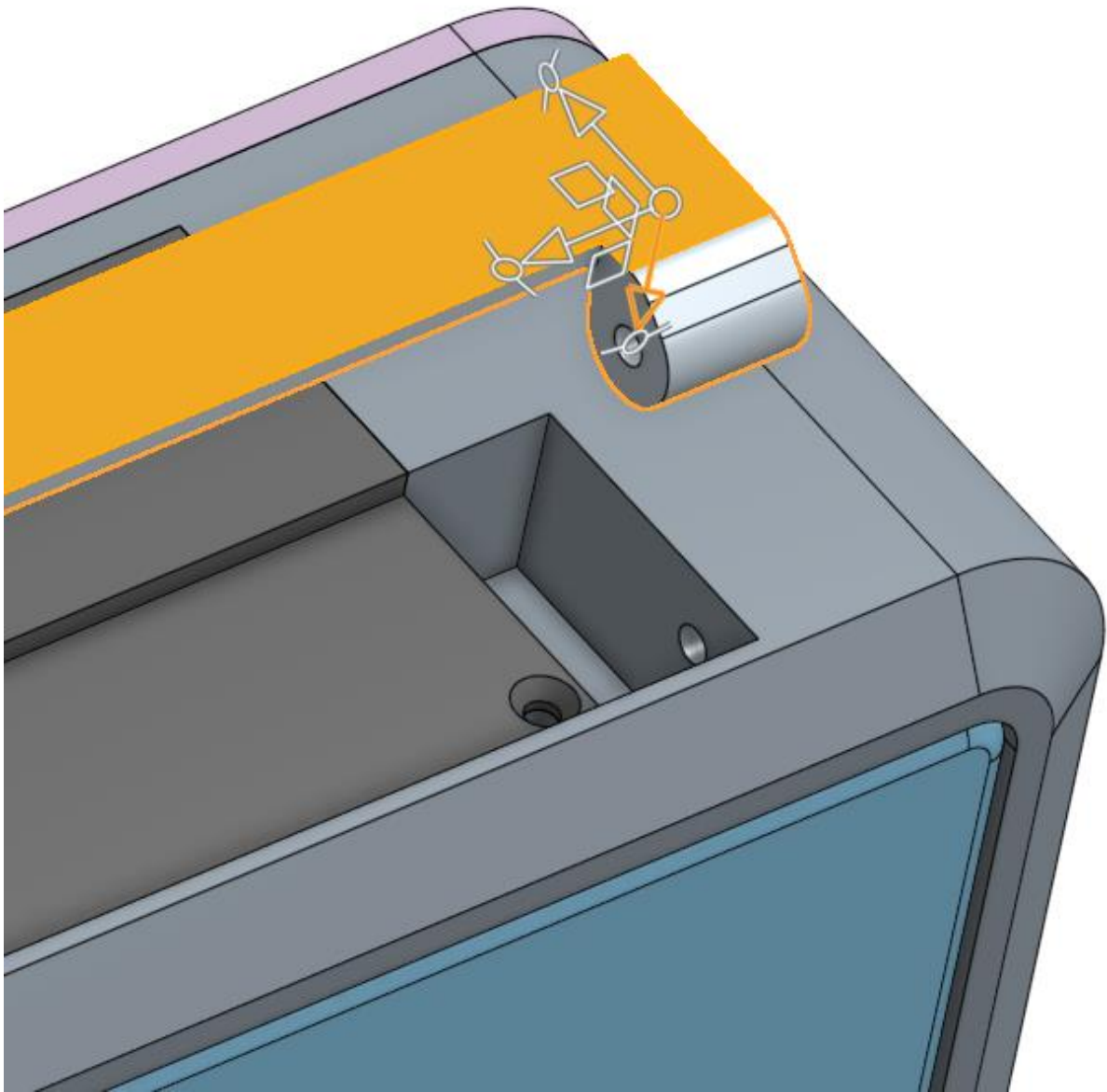

8. Let's start by assembling the stand. We want to be able to swing open the stand to prop the speaker up. Turn the model upside down, and click on the stand. Use the triad to translate it out of place just a bit (this will expose the surfaces we will use for referencing the Mate Connectors):

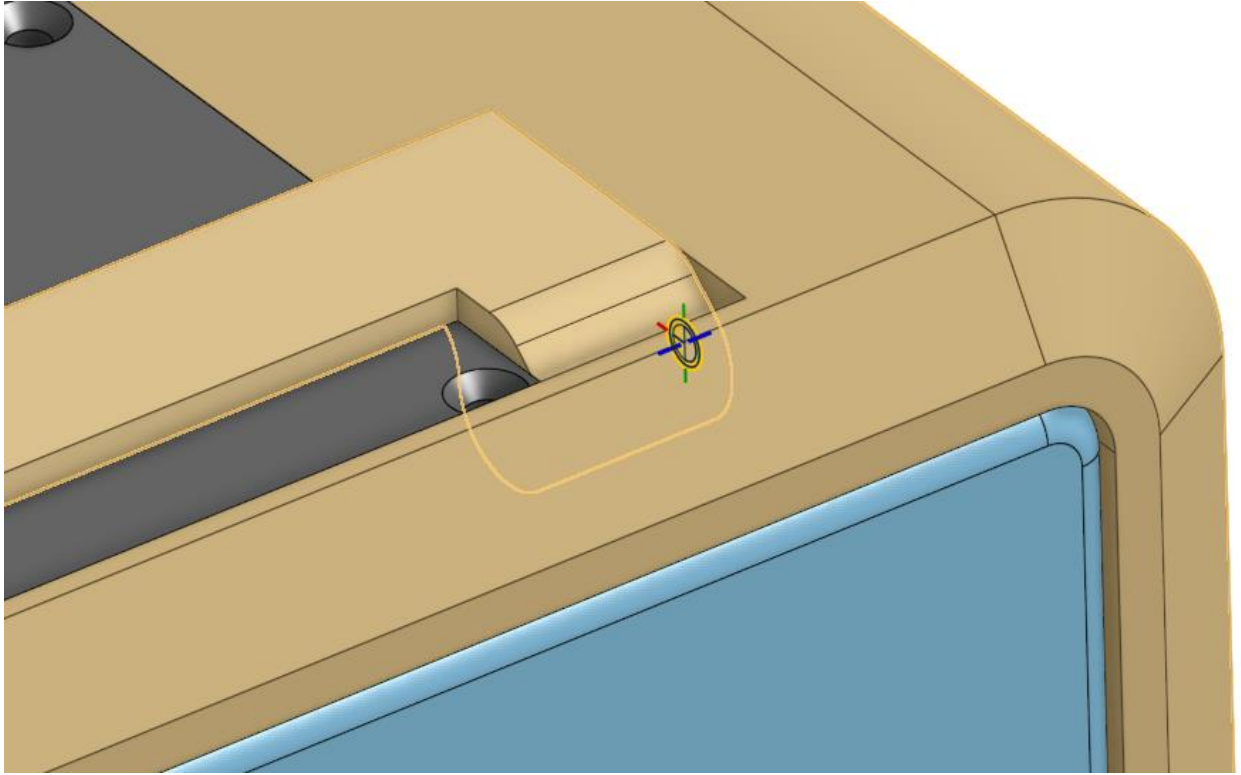

9. Next, create a revolute mate, , by referencing the pin holes in the Stand and in the Frame:



10. Next, let's add limits to the Revolute Mate, so the stand can only open and close 90 degrees. Use the Play button, , to ensure the direction and limits are correct (click on "Reorient secondary axis"  until the direction of rotation is correct):

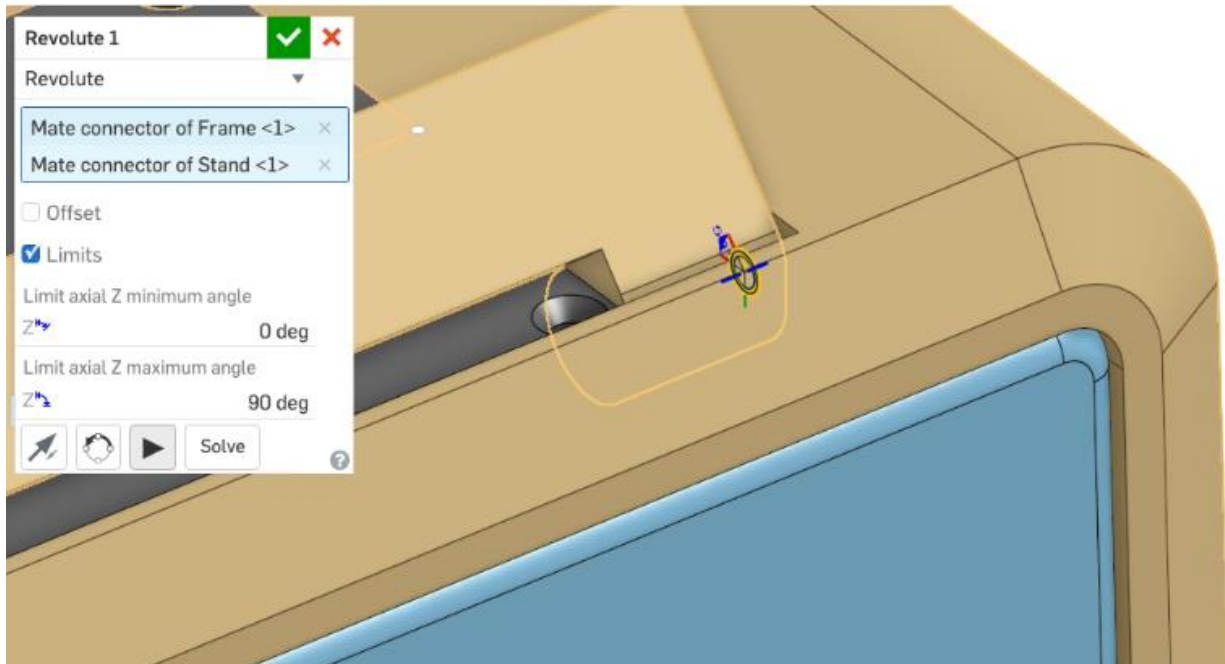

Design Intent Check: Now we're going to be adding the second small speaker and speaker box, along with a lot of screws. How should they be mated? Let's see how we can take advantage of the symmetry of the mates.

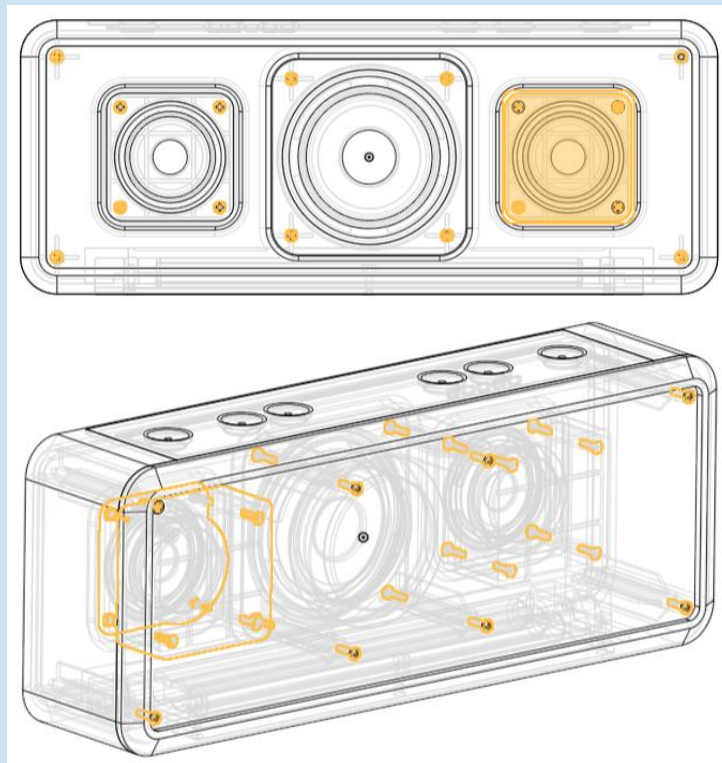

Snap Mode

Next, let's add hardware. To prepare for this, we are going to turn on Snap Mode, using the



button. Snap mode allows Mates to be created “on the fly” as we insert new instances into our assembly, which can save significant time during assembly. For more information, and a video example, see the Onshape help here: <https://cad.onshape.com/help/#snap-mate.htm>

11. Click Insert, select “Browse Documents”, and paste the following link into the search dialog box (<https://cad.onshape.com/documents/577b9ed8e4b0934f53f311a2/w/4b0385496c0459c9b621a638/e/10864ed2c2385416d99b6067>). This should pull up the hardware document for this design:

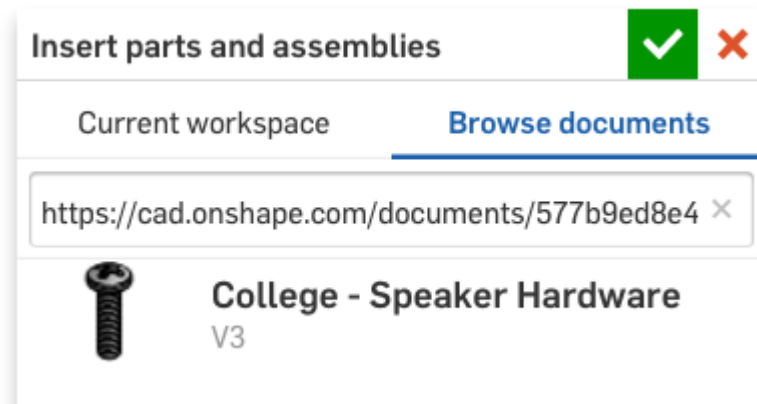

12. Select the document, and then select the button head screw. Now, as you hover over the model, Onshape is automatically “waking up inferred Mate Connectors”. Hover over the Top-Left corner of the small speaker, and the screw will snap in place:



Pro Tip: Remember when we used the [Shift] key on the keyboard to lock into the current geometry selection in the Cantilever Clamp in Week 4? It would help to do so here; hover over the front face of the speaker, and hold [Shift] to see all the inferred Mate Connector locations:

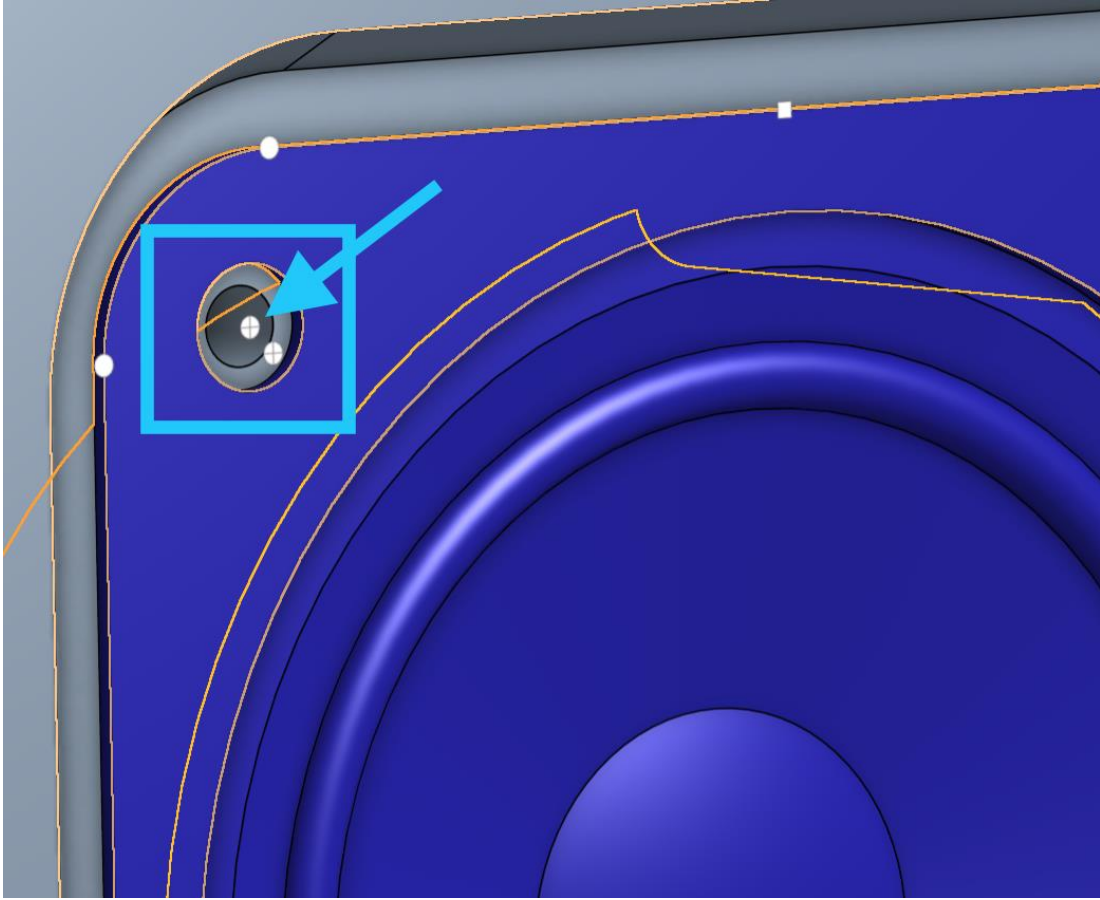

Select the one that the arrow is pointing to. Now, we can just drop the screw in place, and we know for sure that it is going into the right spot:

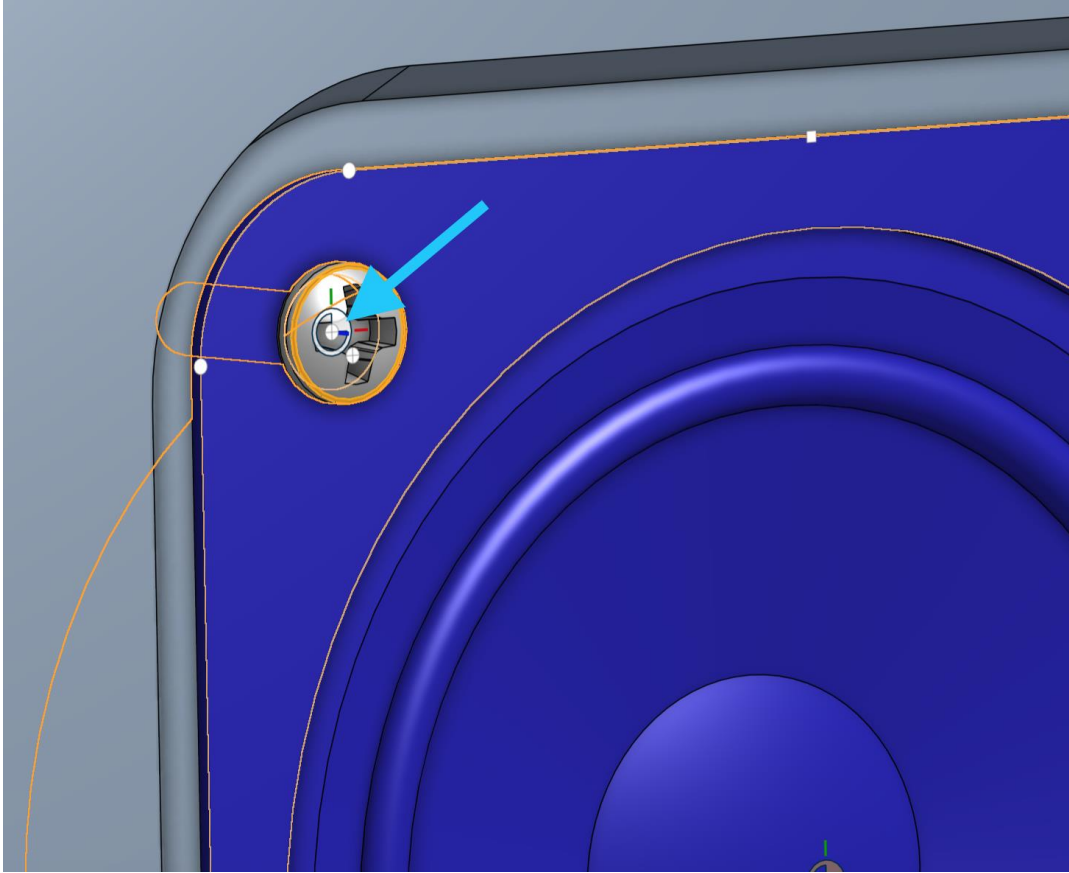

In addition, you can use the “k” key to toggle the hide/unhide the mate connectors, and the “j” key to hide/unhide the mates. Keeping the screen “clean”, by removing unwanted icons, and using keyboard shortcuts like this will save time. And time is money.

13. A single left-click will drop it in place, thus adding the screw to our Parts List and establishing a Fastened Mate:

Instances (10)

- Origin
- 📄 Battery Co... ▨
- 📄 Button Ove... ▨
- 📄 Cover <1> ▨
- 📄 Face <1> ▨
- > 📄 Frame <1> ▨
- 📄 Speaker B... ▨
- 📄 Speaker_la... ▨
- 📄 Speaker_s... ▨
- 📄 Stand <1>
- > 📄 91772A078 <1> 🔗
- ▼ Mate Features (2)
 - > 🔄 Revolute 1
 - > 📄 Fastened 1



14. Let's repeat this process for the next three screws for the small speaker:



15. Next, let's continue using Snap Mode to assemble the same screw to the large speaker:

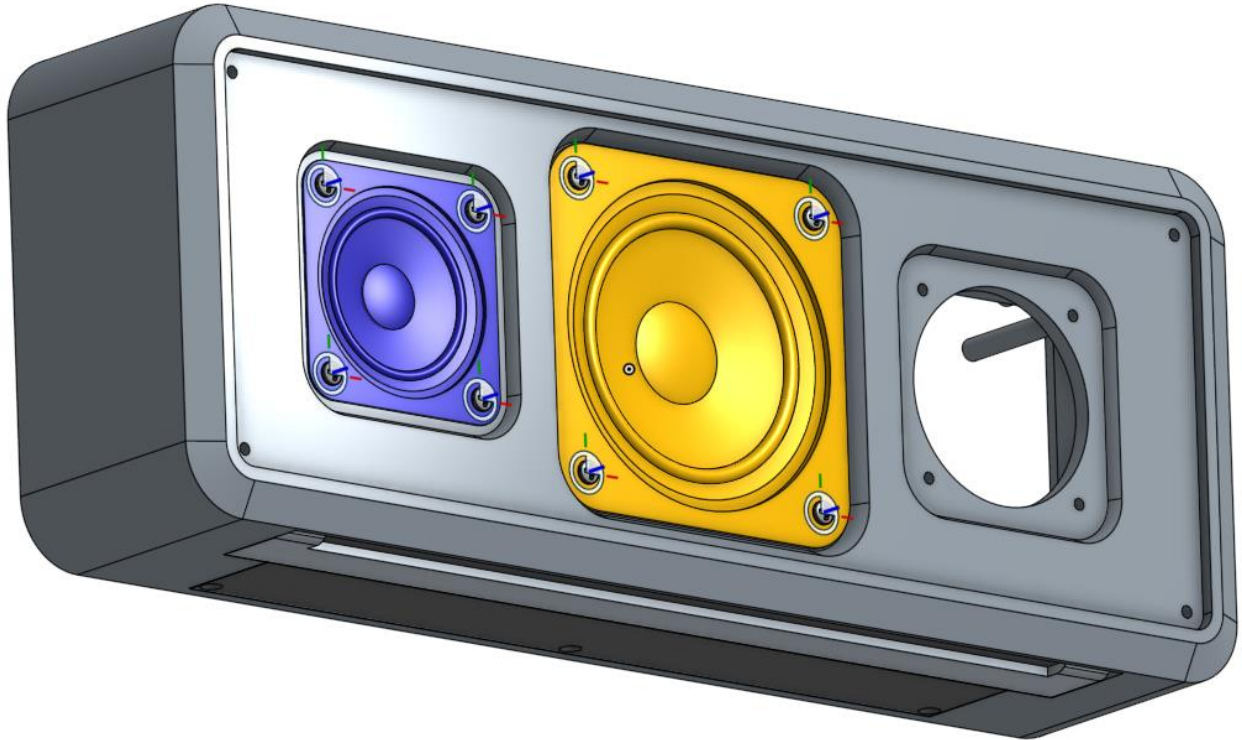

Mate Groups

Next, let's assemble the other small speaker (on the right side), and its speaker box as well. These two parts have been designed "in context", which means in the Part Studio, they are already located in the correct location and orientation relative to each other (on the left side of our bluetooth speaker assembly). Since our design is symmetric, the right side speaker and box pair will look exactly like the left side. In Onshape, we can group them together, which is like creating a subassembly of part instances. In doing this, we can keep their relative locations the same, and we can assemble them using less Mates.

16. Start by inserting the small speaker and speaker box from our design, and clicking the green check box immediately so they are put in their default locations. It helps to hide all parts except for the frame first because the second speaker and its box will be exactly where the left speaker is:

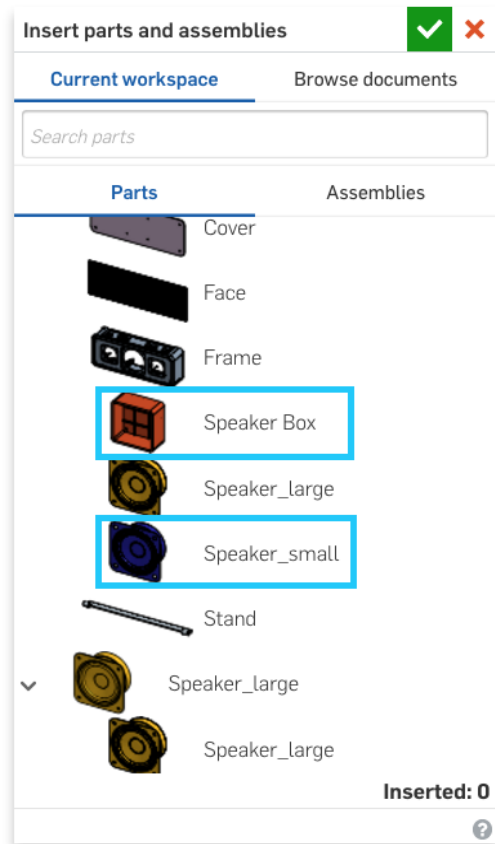
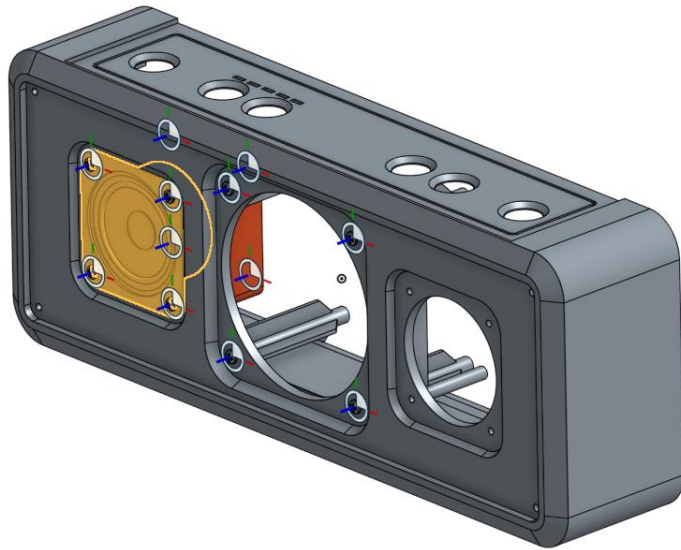

17. Now, select the Group tool, , and select the recently inserted speaker and speaker box. Rename the group to something descriptive like “small speaker & box”:

small speaker & box

| | |
|-------------------|--------------------------|
| Speaker Box <2> | <input type="checkbox"/> |
| Speaker_small <2> | <input type="checkbox"/> |

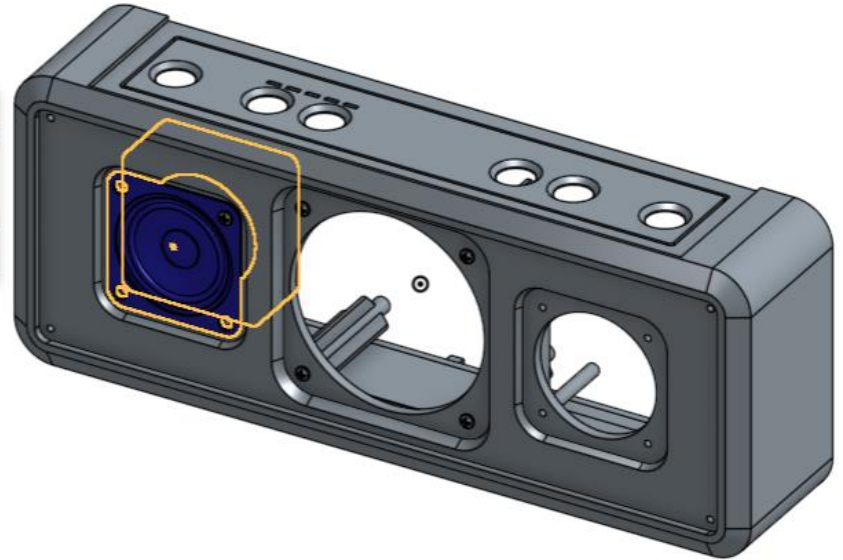

18. Now, you may move this group using the triad, and notice how the speaker and speaker box stay in the same position relative to each other. Unhide the other parts, and we should now have an assembly that looks like this:

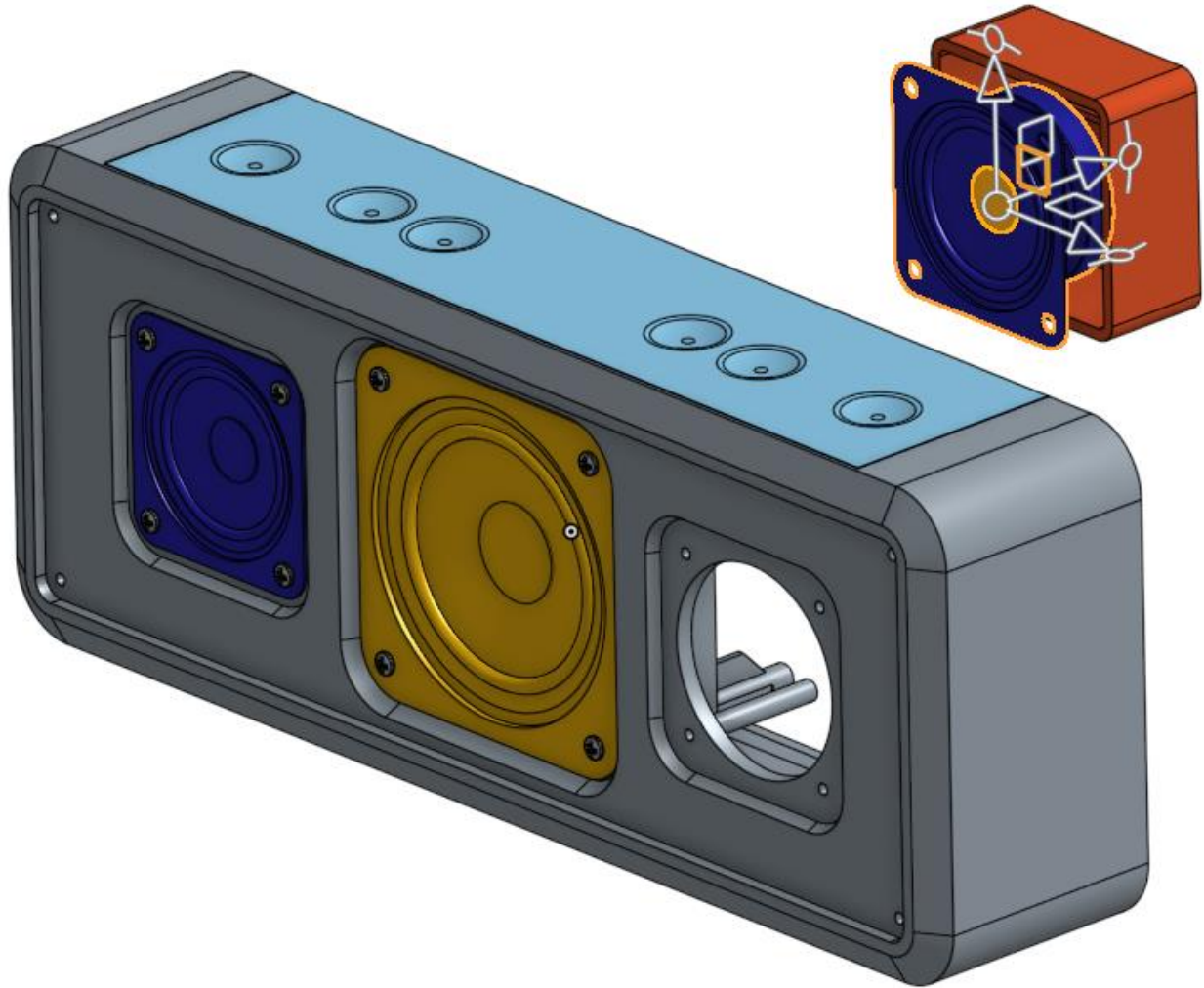

19. Now, we can assemble this group in place, either by referencing geometry from the speaker or from the speaker box. We will use the speaker. Let's create a fastened mate,



, between the back face of the speaker, and the front face of the Frame like this:

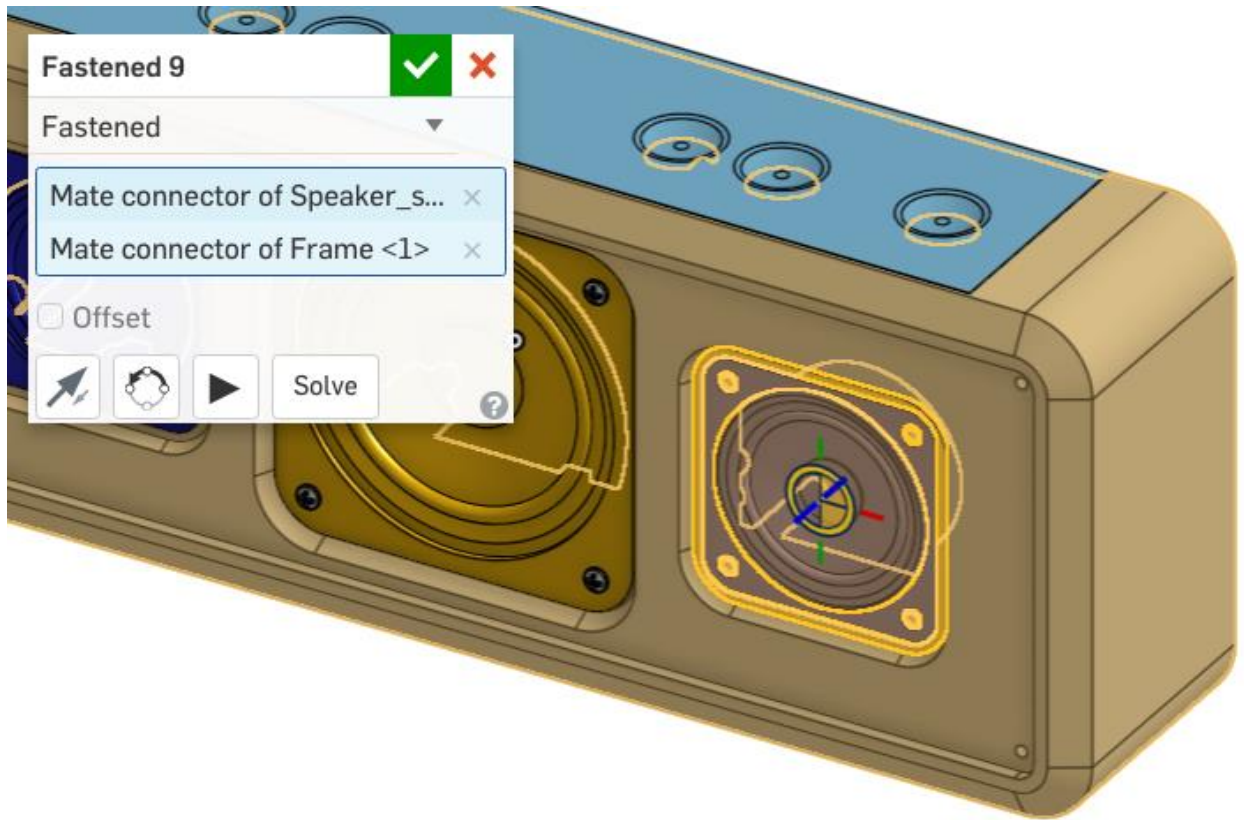

20. Since the speaker box is grouped to the speaker, it is now assembled in place as well:

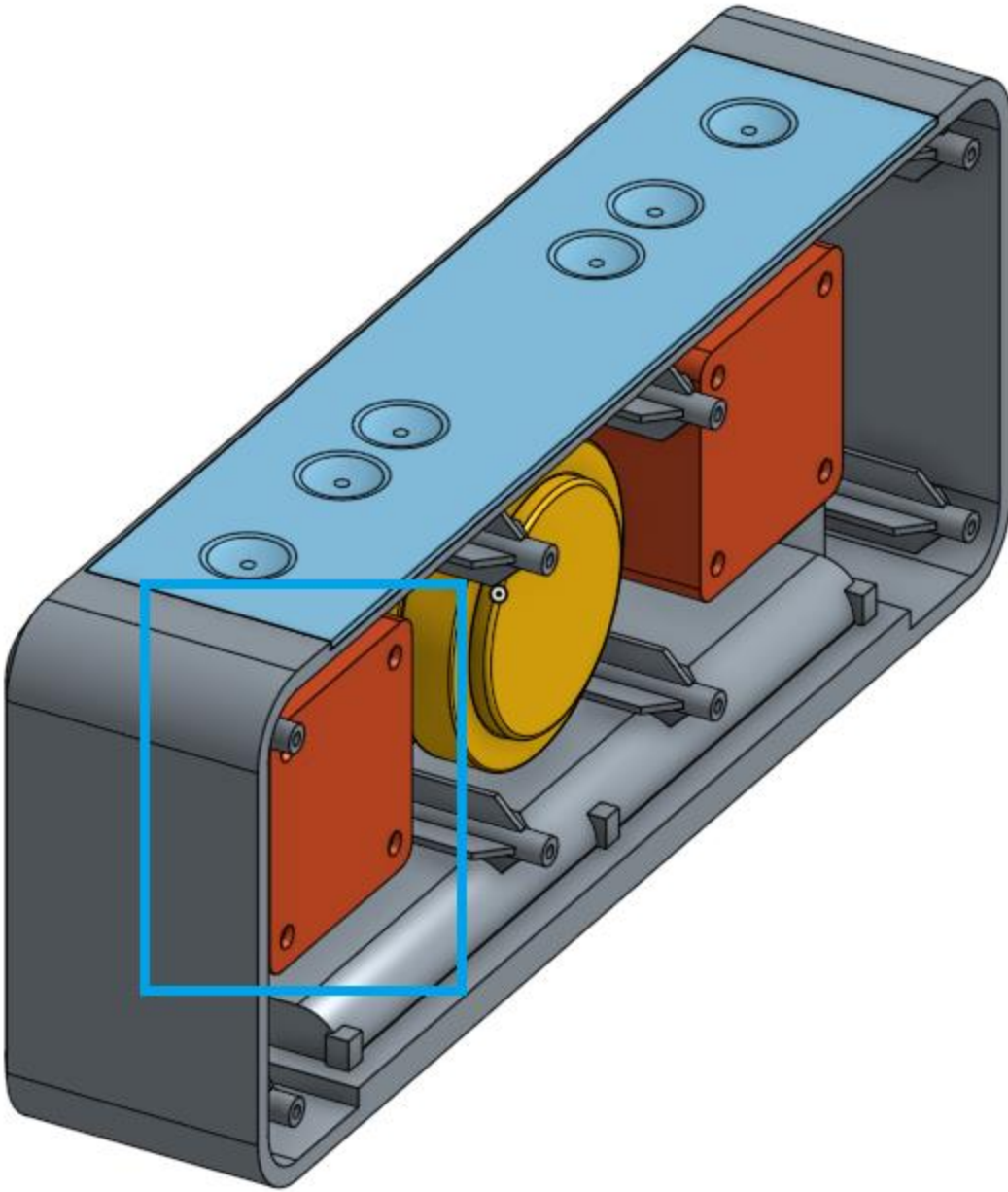

21. Once again, using Snap Mode, assemble 4 button head screws to the second small speaker:

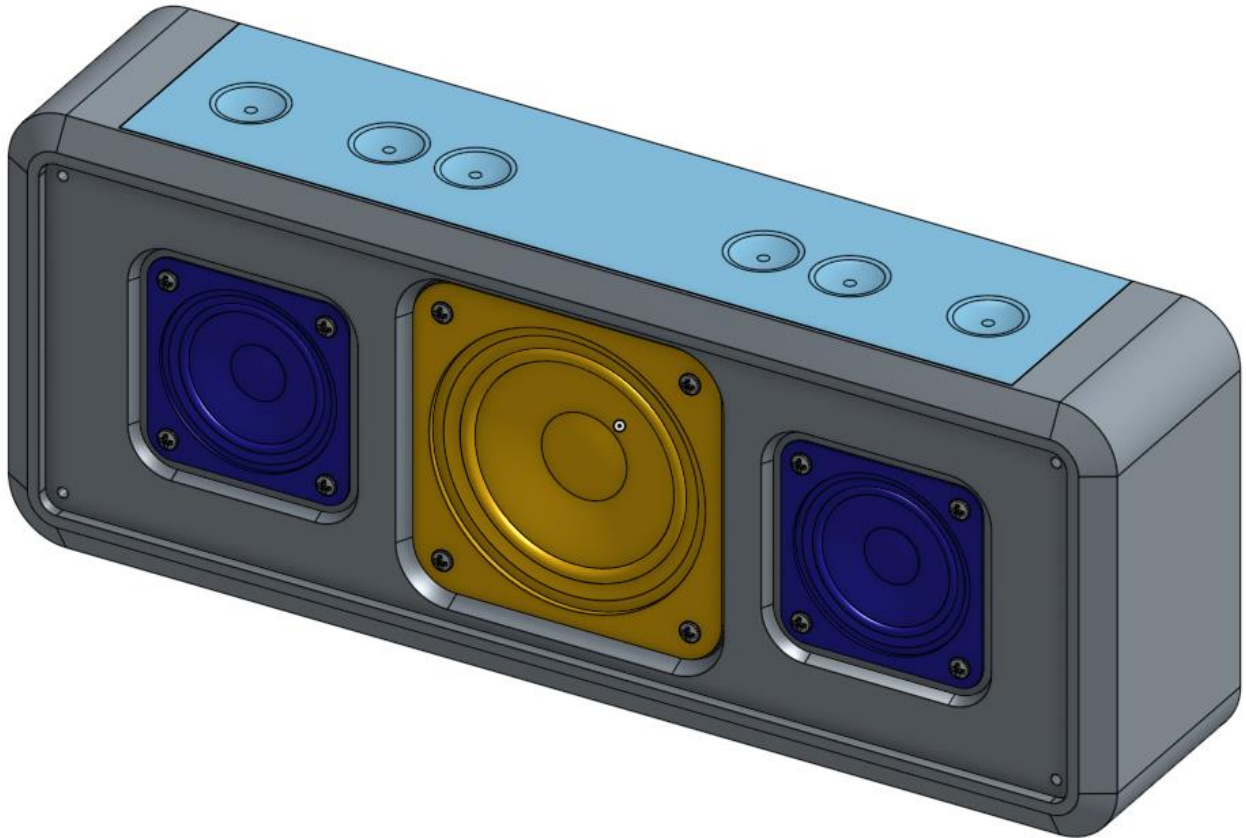

Replicate

Now that we have the speaker boxes in place, we can assemble the hardware. For this, we are going to use Onshape's Replicate tool . The Replicate tool takes a seed part or parts (such as a screw) as input and locates geometry identical to that which the seed is mated to (such as screw holes). This is a huge time-saver. For more information, see the Onshape help here: <https://cad.onshape.com/help/#replicate.htm>

22. First, let's assemble a flathead screw (from our speaker hardware document), to the left speaker box, using Snap Mode:

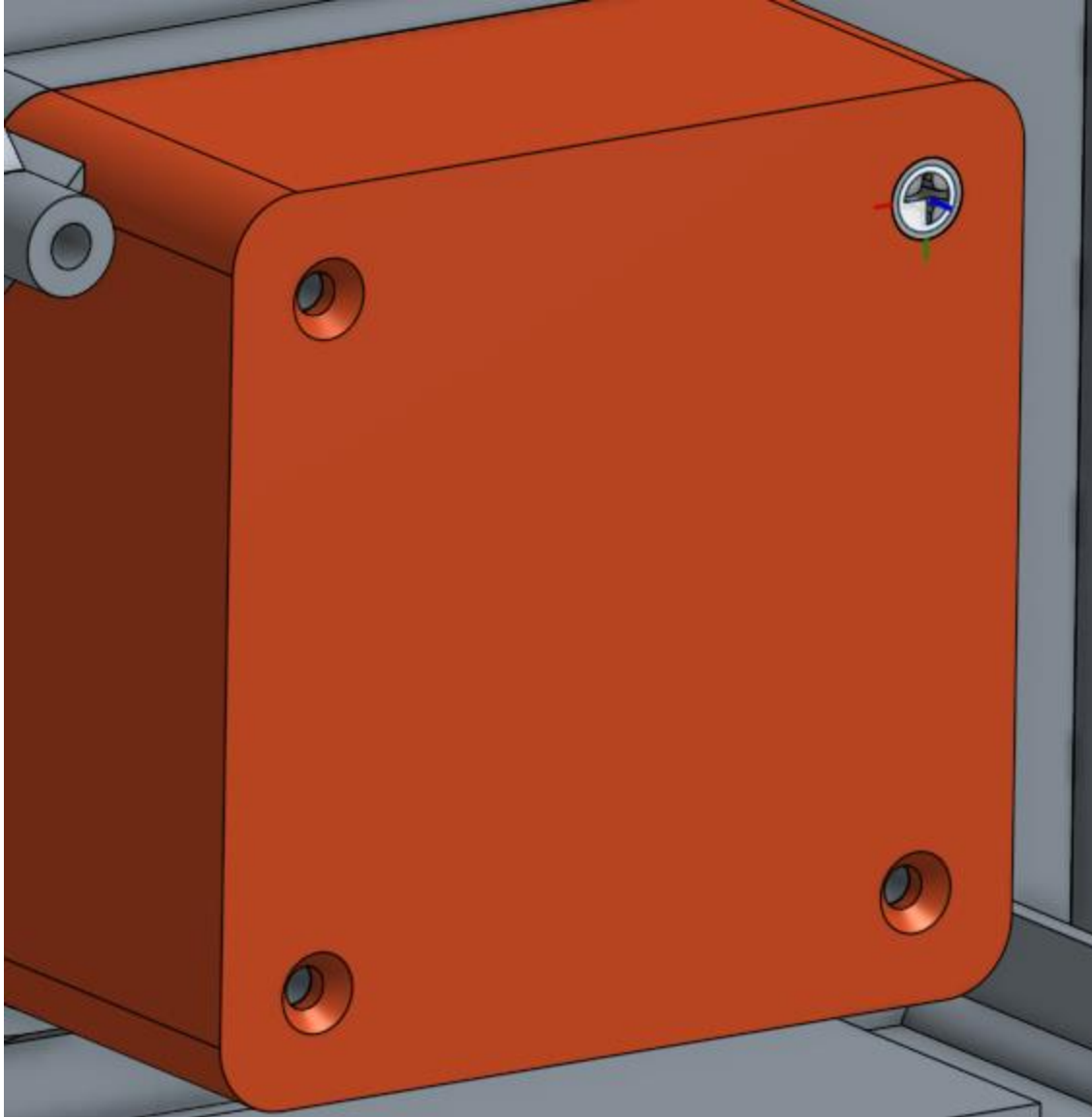

23. Next, select the Replicate tool, . Use the flathead screw as the “seed instance”, and select the faces of both speaker boxes as the reference face:

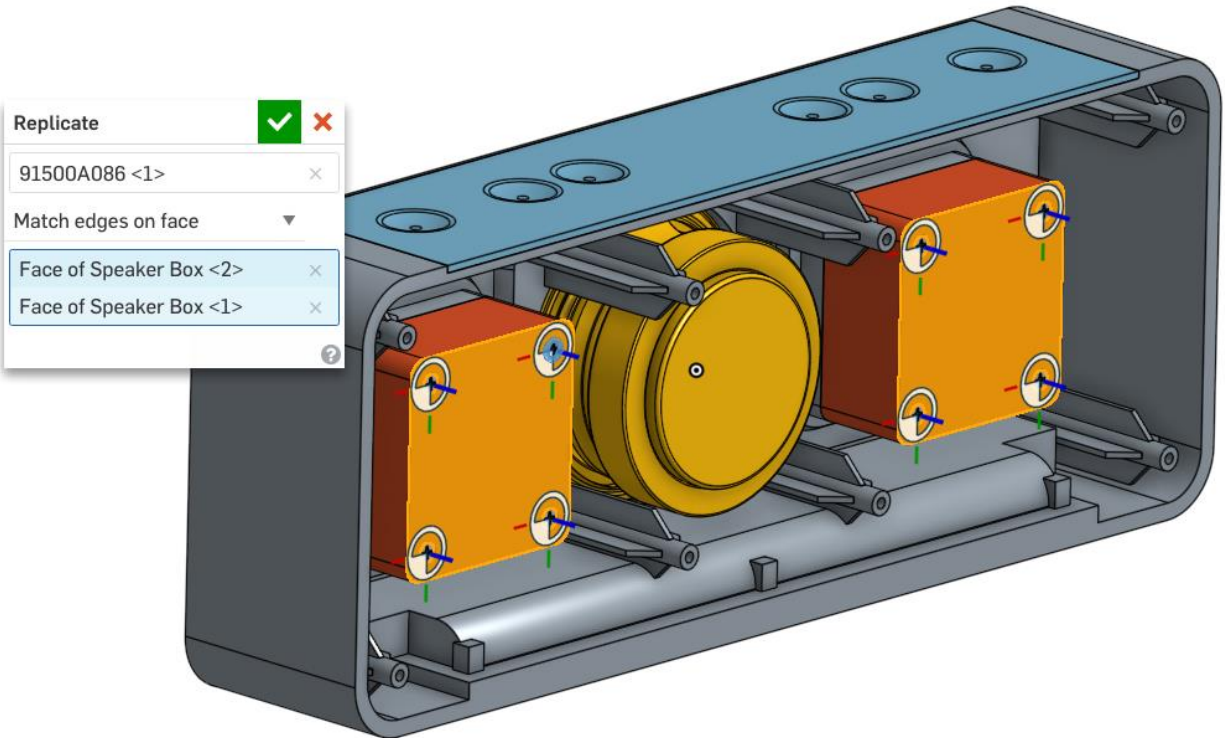

24. Click the Green checkbox. Since all the circular edges (holes) in the two speaker boxes are identical, the Replicate tool will automatically add and mate the flathead screws to the remaining holes. There should be seven more instance of the flathead screw in our Parts List, and there should be seven more fastened Mates:

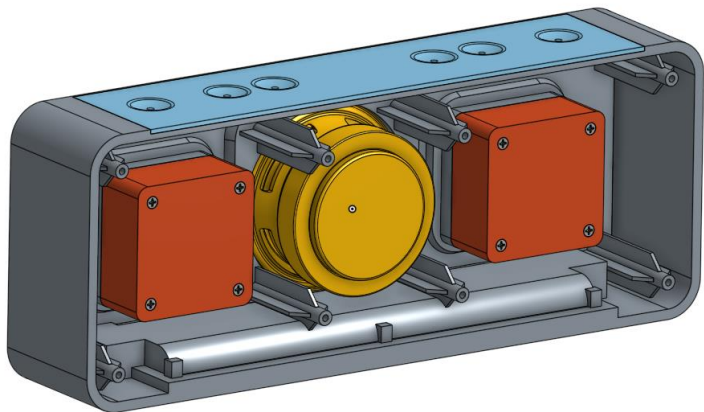
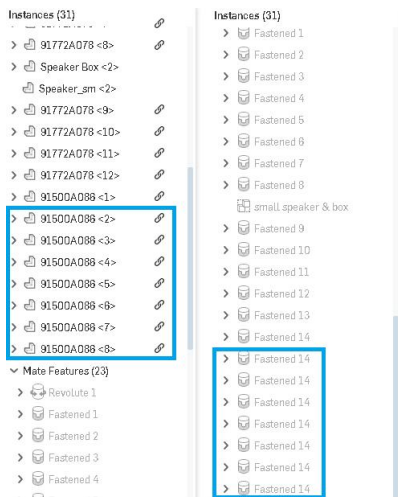

Pro Tip: As you can imagine, this method would have saved us some time assembling the hardware on the front of the speaker as well. For the sake of learning, we went through the

“manual way” first, but now that we know how to use replicate, make a note to take advantage of it any time you can! Less time spent on mundane tasks like this means more time spent on designing!

25. Next, let's unhide the cover, and assemble a button head screw using Snap Mode:

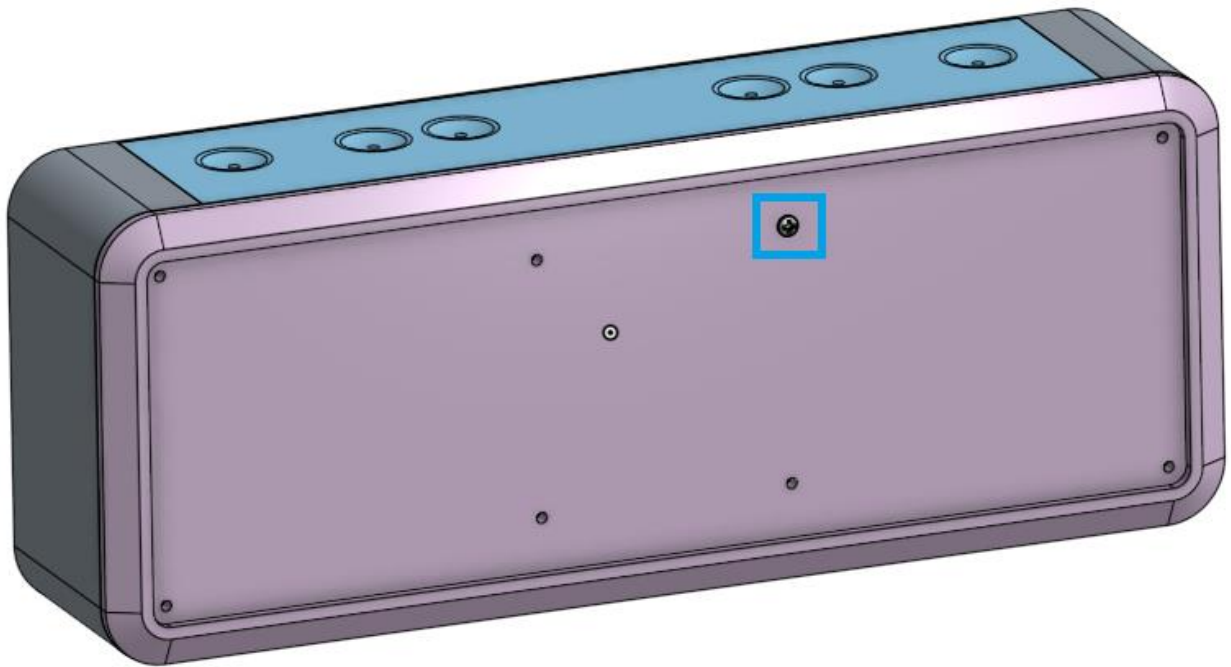

26. Next, replicate that screw to the other holes in the cover:

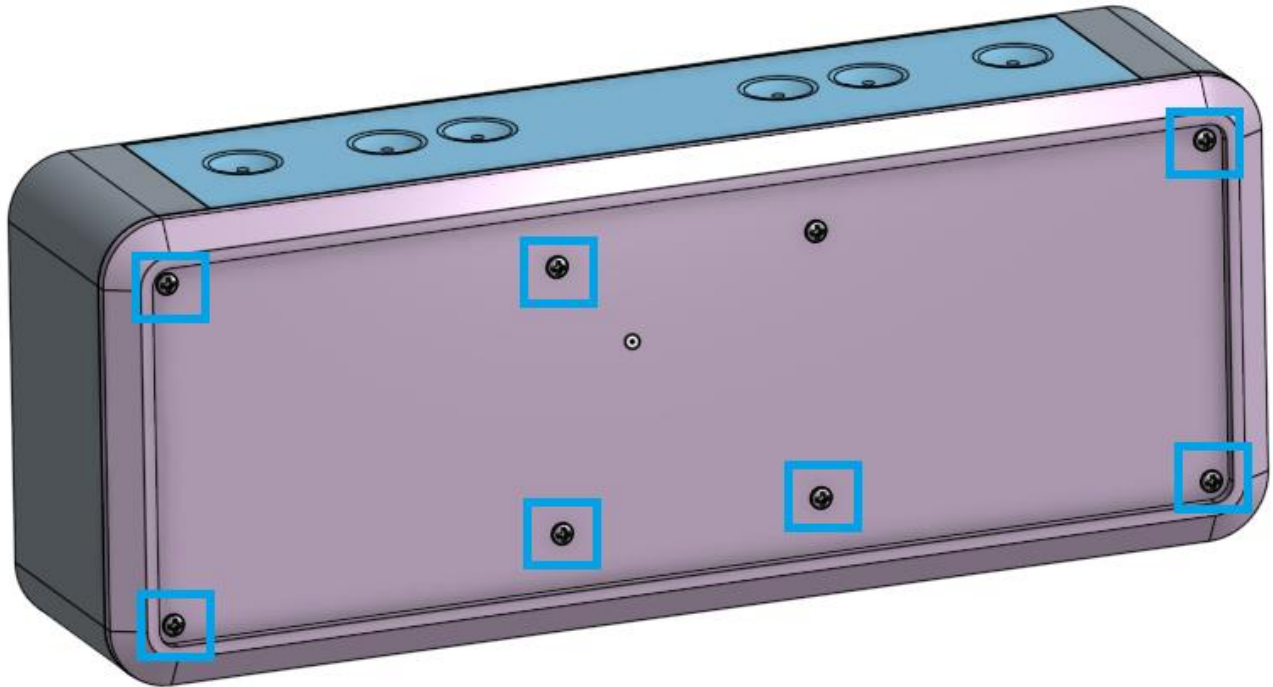

27. Next, let's assemble the batteries. To do this, we're going to explicitly create a Mate Connector (instead of creating one "on the fly") in the Part Studio. Navigate to the Bluetooth Speaker Part Studio, and unhide our battery compartment sketch. If you recall, we named the sketch "Battery Compartment Sketch", so finding it can be done quite easily by searching for the text "battery". In this case, we only need to type is the letters "ba", and it pops up:

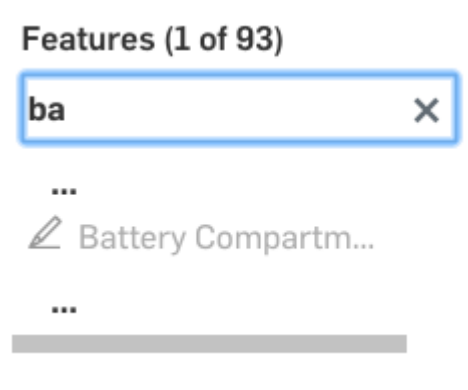

28. Next, unhide the sketch. Now, using this sketch as a reference, create a new Mate Connector in the middle of the sketch construction line, making sure the blue axis is pointing towards the back of the Frame (you can change the direction using the arrows ). Rename it "Battery Mate Connector":

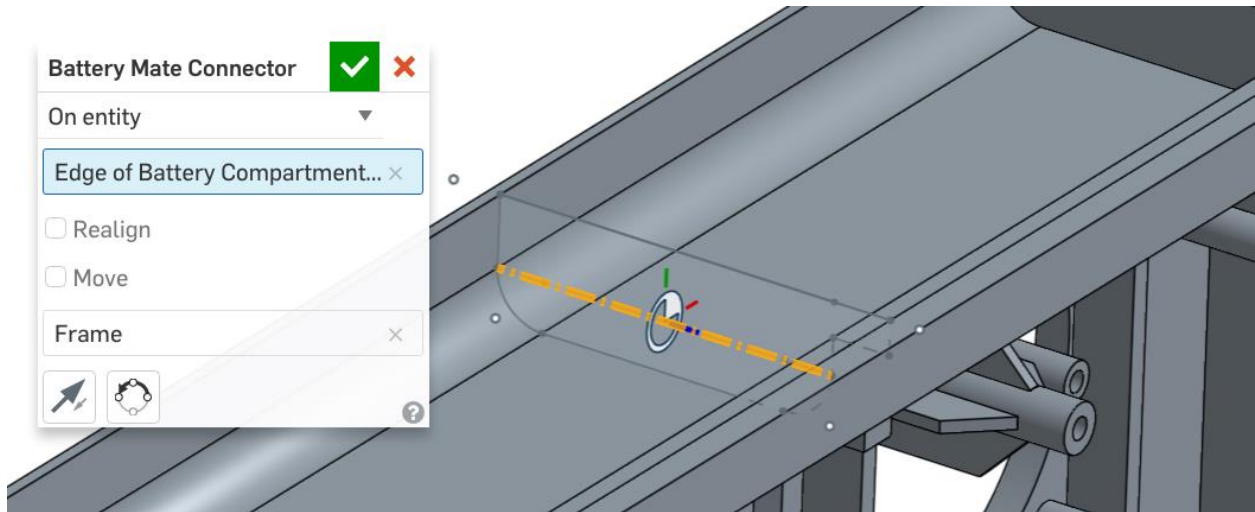

29. Now, we can assemble the batteries. Navigate to the Assembly tab, and hide everything except for the frame to clean up the screen. This can be done easily by right-clicking on the Frame in our Parts list, and selecting "Hide other parts:".

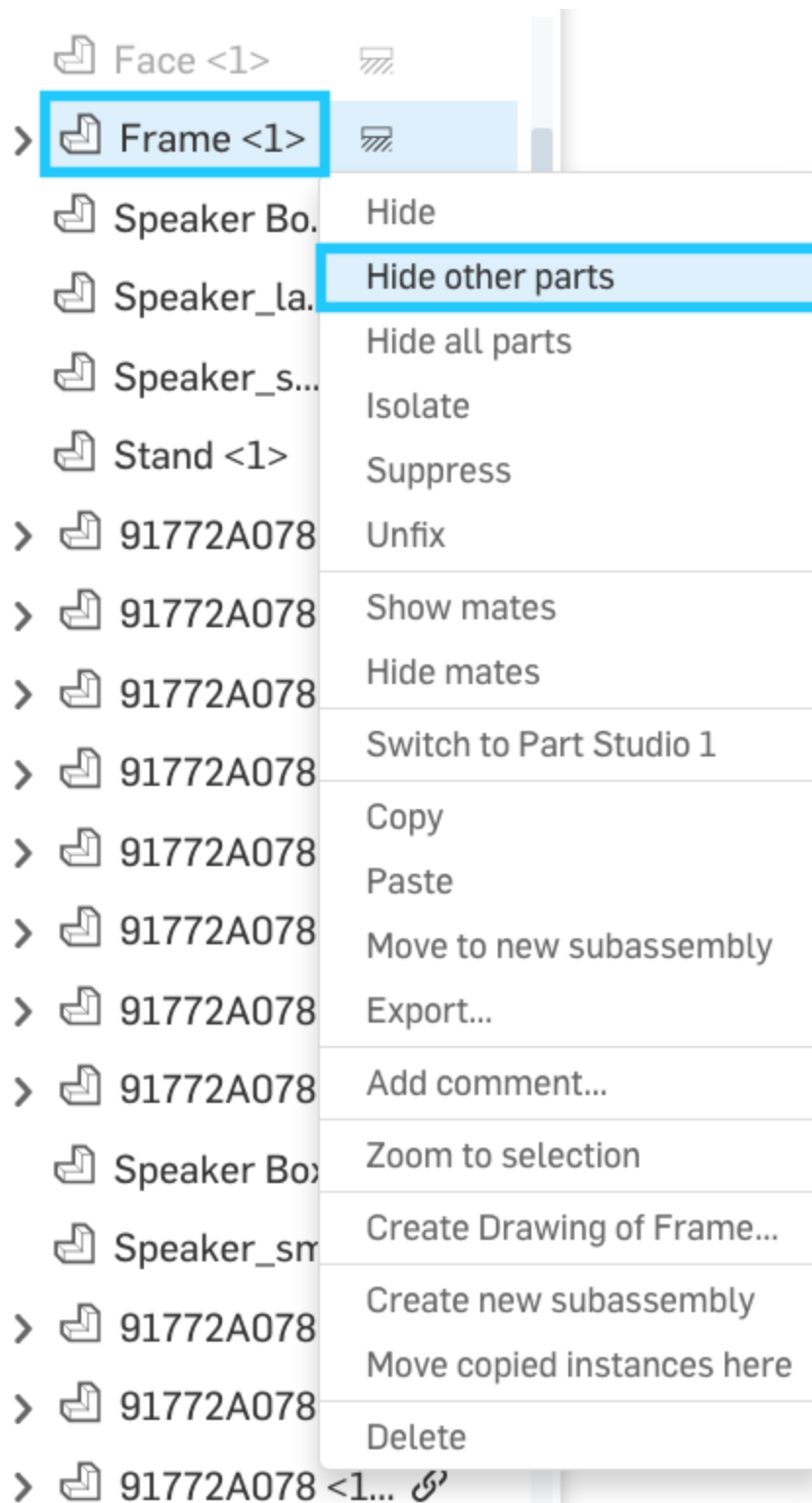

30. Navigate to the Frame part in the Parts List, expand it, and unhide our “Battery Mate Connector”. This will make it easy to select:

Instances (31)

- Face <1>
- Frame <1>
- Battery Mate Co... Battery Mate Connector**
- Speaker Bo...
- Speaker_la...
- Speaker_s...
- Stand <1>
- > 91772A078 <1>
- > 91772A078 <2>
- > 91772A078 <3>
- > 91772A078 <4>
- > 91772A078 <5>
- > 91772A078 <6>
- > 91772A078 <7>
- > 91772A078 <8>
- Speaker Box <2>
- Speaker_small <2>

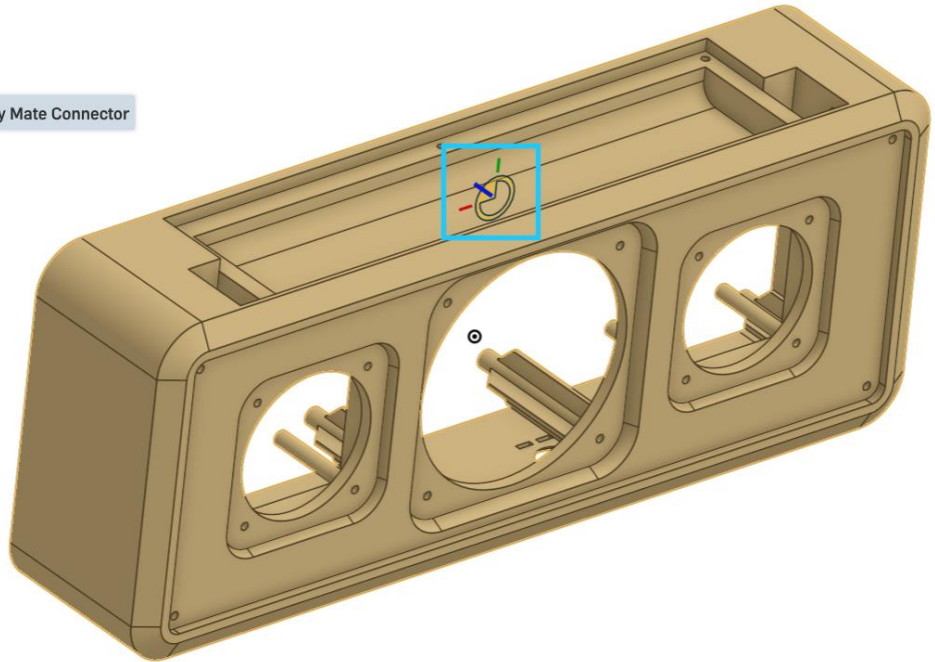

31. Now, make sure Snap Mode is on, and insert the battery part:

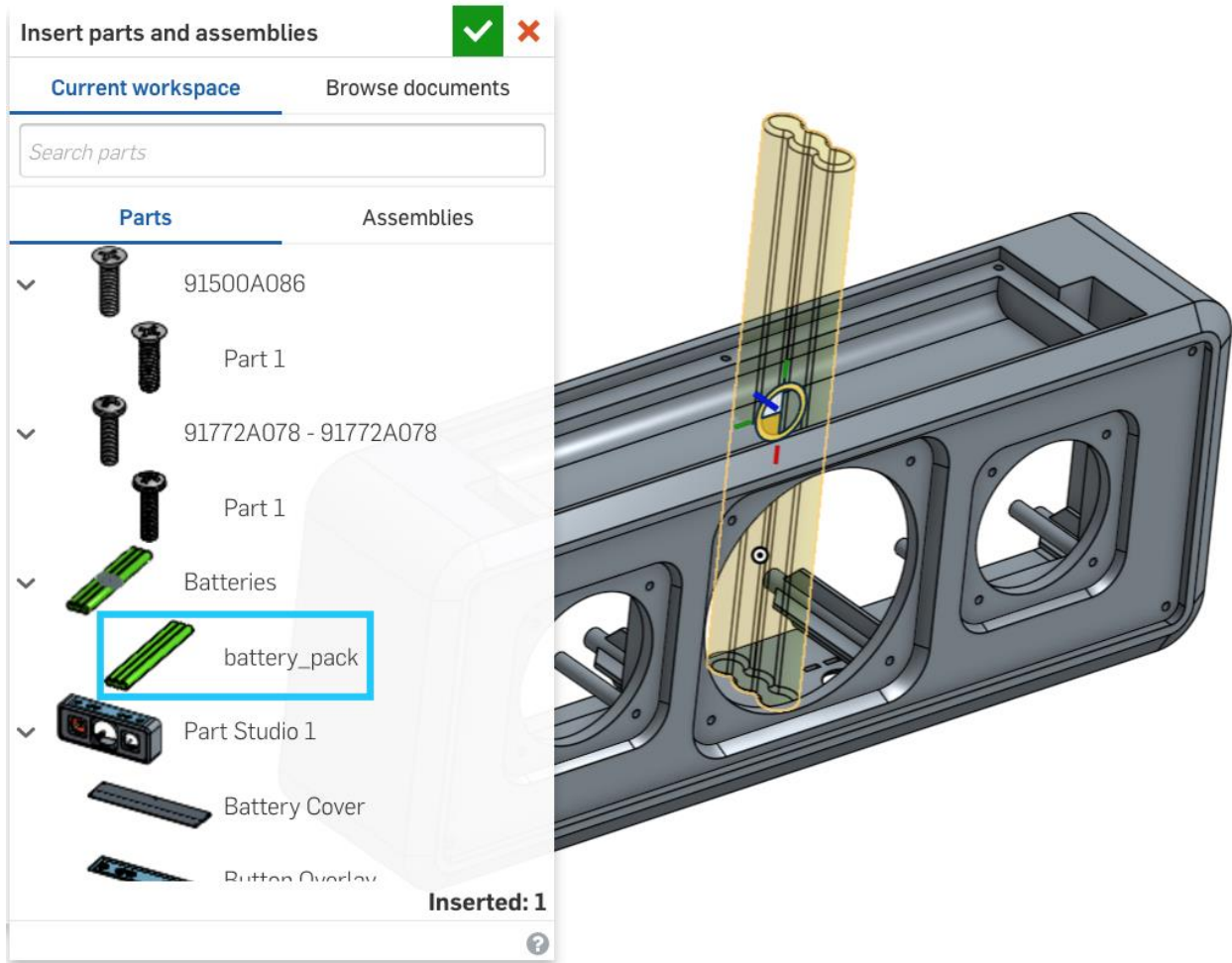

32. In this case, our batteries are rotated 90 degrees by default (this is due to the orientation of the green and red axis on the Mate Connector). Before clicking, rotate your batteries while in Snap Mode using the "q" key:

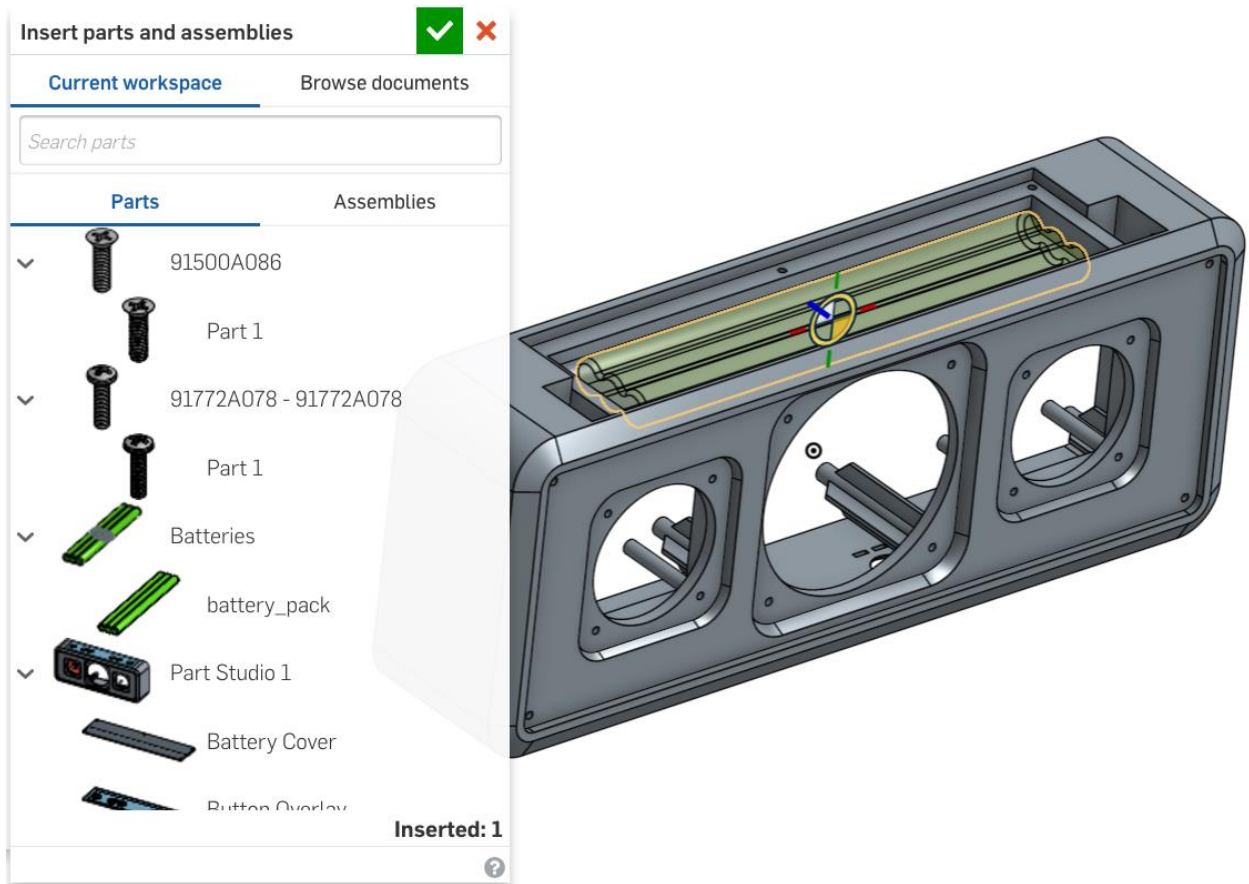

33. Now, just click the screen with the left mouse button, and the batteries will be dropped in place:

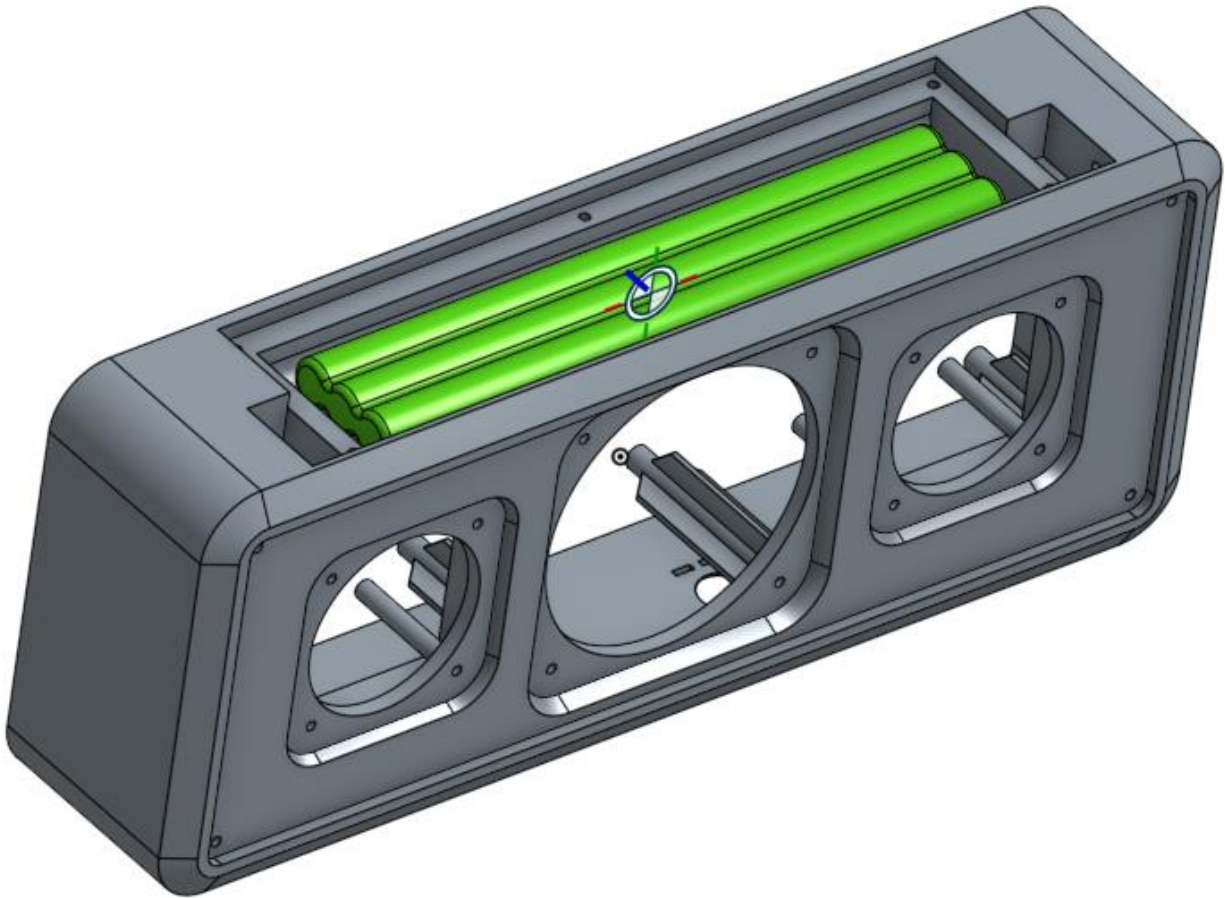

34. Next, unhide our battery cover, and assemble a flathead screw into one of the chamfered holes:

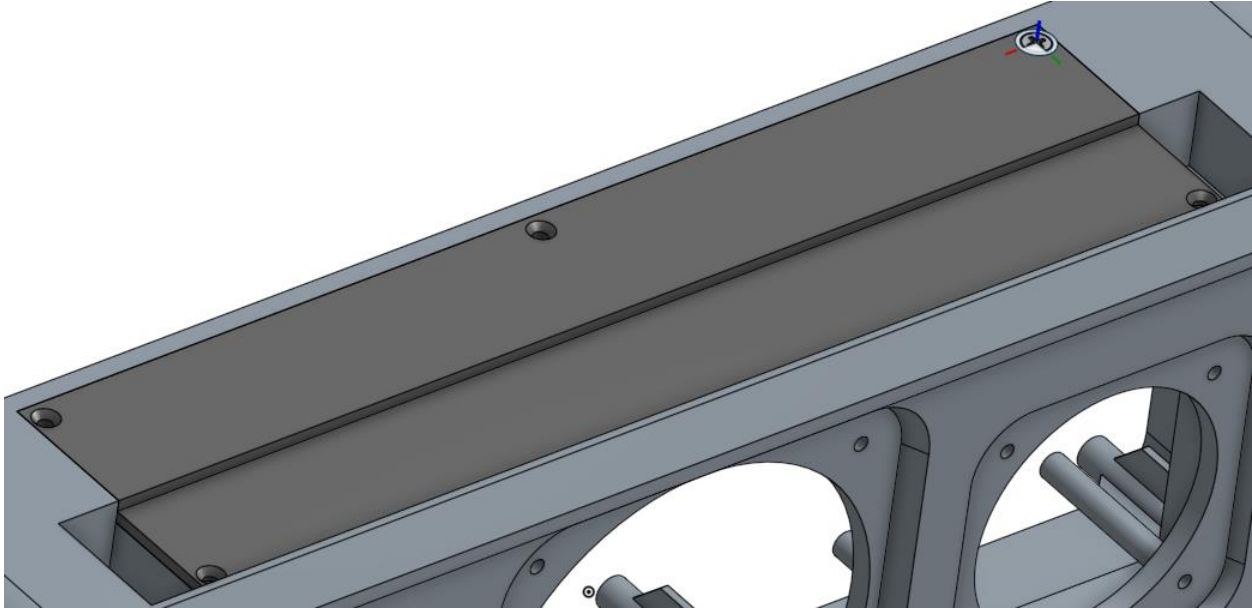

35. Next, Replicate the screw to the rest of the holes in the cover, by referencing both faces:

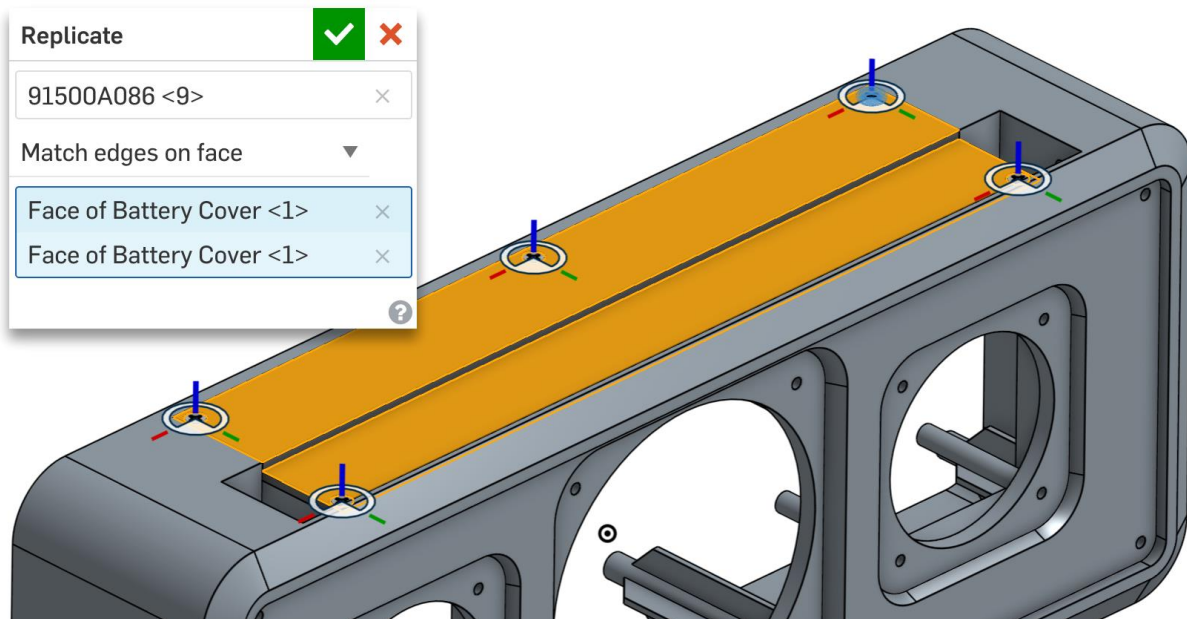

36. Finally, let's show all parts by right-clicking in the empty white space in the graphics screen and selecting "Show all parts":

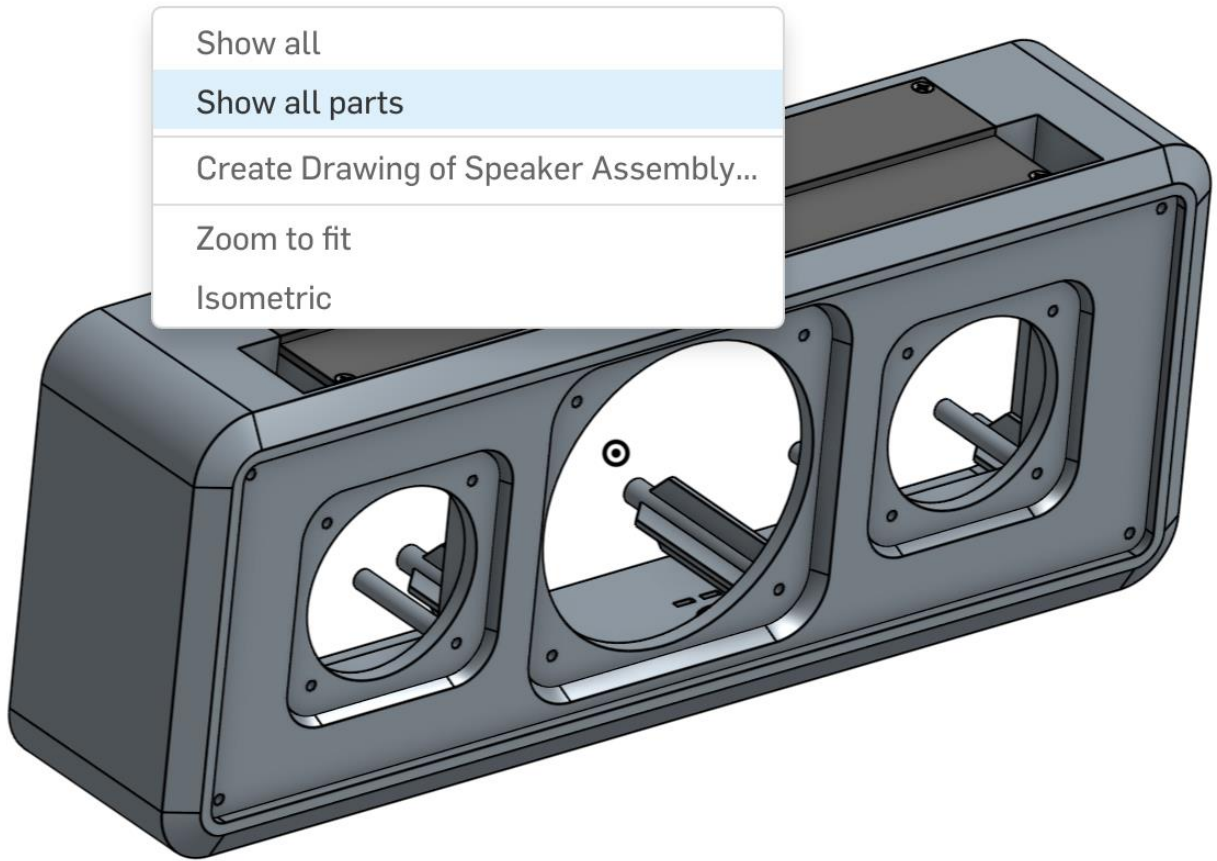

37. Congratulations! Our completed Bluetooth Speaker Assembly should now look like this:

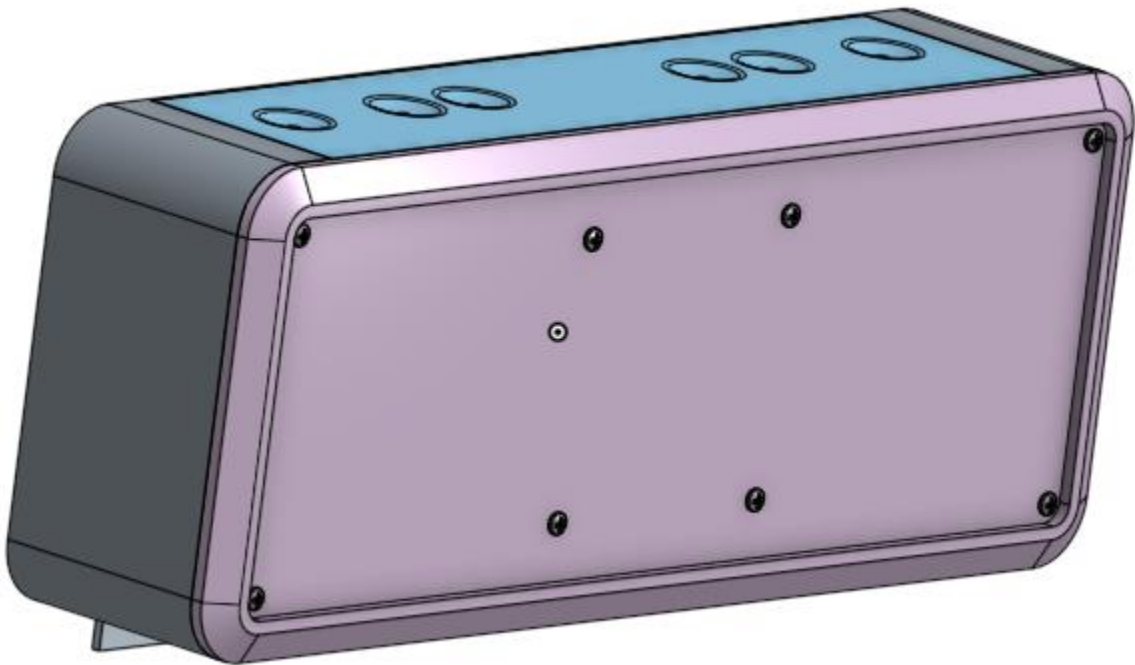
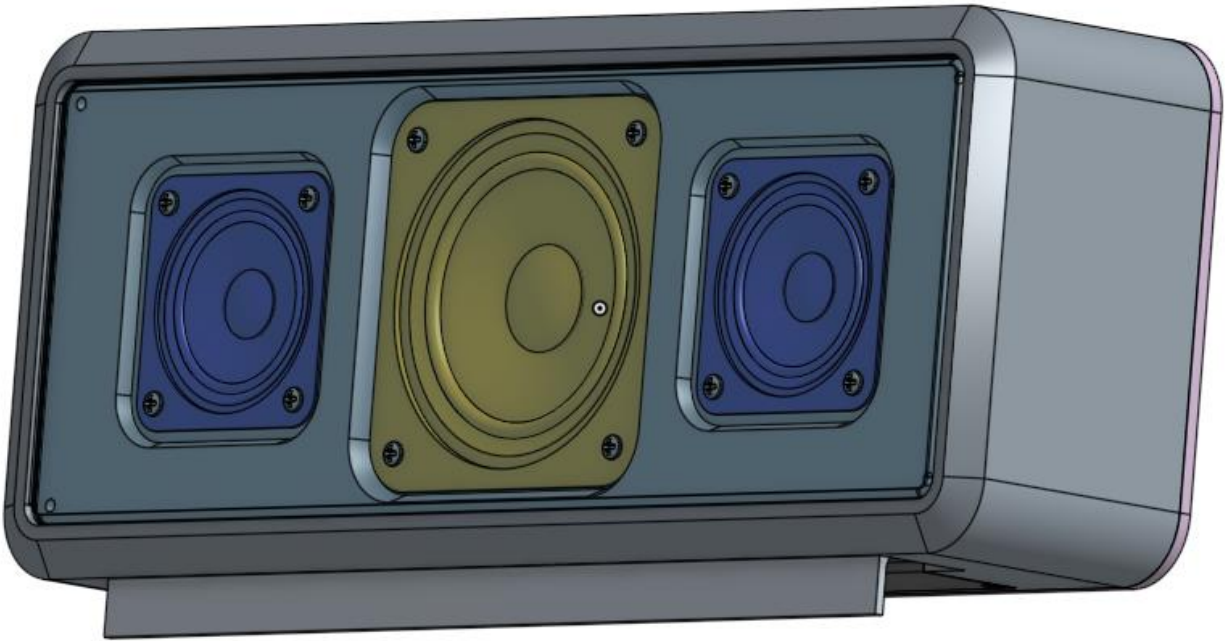

Summary

Let's take a second to reflect what we learned in this lesson.

1. We learned how to insert and mate parts into an Assembly using Snap Mode.

2. We were able to group parts and create the Assembly with fewer Mates.
3. We were able to replicate Mates.

Good job! Next week, we'll be starting our final project, the Chopper!